

Operator's Manual

300 Power Drive



⚠ WARNING!

Read this Operator's Manual carefully before using this tool. Failure to understand and follow the contents of this manual may result in electrical shock, fire and/or serious personal injury.



Table of Contents

Recording Form for Machine Serial Number.....1

General Safety Information

 Work Area Safety.....2

 Electrical Safety.....2

 Personal Safety.....2

 Tool Use and Care.....3

 Service.....3

Specific Safety Information

 Foot Switch Safety.....3

 Machine Safety.....3

Description and Specifications, Standard Equipment

 Description.....4

 Specifications.....4

Machine Assembly

 Mounting on 1206 Stand.....5

 Mounting 311A Carriage and Tools.....5

Machine Inspection.....6

Machine and Work Area Set-Up.....7

Operating Instructions Using Hand Tools

 Installing Pipe in Power Drive.....8

 Cutting Pipe with Hand Cutter.....8

 Reaming Pipe with Hand Reamer.....9

 Threading Pipe with Hand Threader.....9

 Removing Pipe from Power Drive.....10

Operating Instructions Using Carriage-Mounted Power Drive Tools

 Cutting Pipe with No. 360 Cutter.....11

 Reaming Pipe with No. 341 Reamer.....11

 Threading Pipe with Quick-Opening or Self-Opening Die Head.....12

 Installing Dies in Quick-Opening Die Head (R.H. & L.H.).....13

 Installing Dies in Self-Opening Die Head (R.H. Only).....14

 Checking Thread Length.....14

Operating Instructions Using Geared Threaders

 Installing Nos. 141 and 161 Geared Threaders (Close-Coupled Method).....16

 Threading Using Nos. 141 and 161 Geared Threaders (Close-Coupled Method).....17

 Installing Nos. 141 and 161 Geared Threaders Using No. 840A Universal Drive Shaft.....18

 Threading Using Nos. 141 and 161 Geared Threaders with No. 840A Universal Drive Shaft.....19

No. 819 Nipple Chuck

 Short or Close Nipple Threading Procedures.....19

Accessories.....20

Maintenance Instructions

 Jaw Insert Replacement.....21

 Lubrication.....21

 Motor Brush Replacement.....21

 Motor Replacement.....21

Machine Storage.....21

Service and Repair.....21

Wiring Diagram.....22

Wiring Schematics.....23

Lifetime Warranty.....Back Cover

300 Power Drive



Model **300 Complete** pictured above including Stand, Threading Carriage, Tool Tray and Oiler.



300 Power Drive

Record Serial Number below and retain product serial number which is located on nameplate.

Serial
No.

--	--

General Safety Information

WARNING! Read and understand all instructions. Failure to follow all instructions listed below may result in electric shock, fire, and/or serious personal injury.

SAVE THESE INSTRUCTIONS!

Work Area Safety

- **Keep your work area clean and well lit.** Cluttered benches and dark areas invite accidents.
- **Do not operate power tools in explosive atmospheres, such as in the presence of flammable liquids, gases, or dust.** Tools create sparks which may ignite the dust or fumes.
- **Keep bystanders, children, and visitors away while operating a tool.** Distractions can cause you to lose control.
- **Keep floors dry and free of slippery materials such as oil.** Slippery floors invite accidents.
- **Guard or barricade the area when work piece extends beyond machine.** A guard or barricade that provides a minimum of three (3) feet clearance around the work piece will reduce the risk of entanglement.

Electrical Safety

- **Grounded tools must be plugged into an outlet, properly installed and grounded in accordance with all codes and ordinances. Never remove the grounding prong or modify the plug in any way. Do not use any adapter plugs. Check with a qualified electrician if you are in doubt as to whether the outlet is properly grounded.** If the tool should electrically malfunction or break down, grounding provides a low resistance path to carry electricity away from the user.

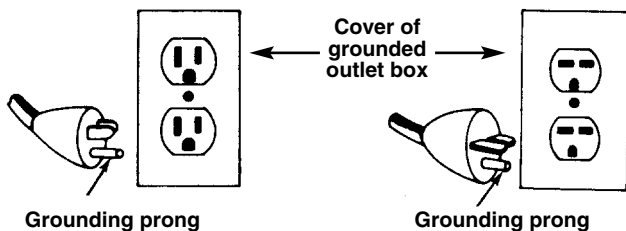

- **Avoid body contact with grounded surfaces.** There is an increased risk of electrical shock if your body is grounded.
- **Don't expose electrical tools to rain or wet conditions.** Water entering a tool will increase the risk of electrical shock.

- **Do not abuse cord. Never use the cord to carry the tools or pull the plug from an outlet. Keep cord away from heat, oil, sharp edges or moving parts. Replace damaged cords immediately.** Damaged cords increase the risk of electrical shock.
- **When operating a power tool outside, use an outdoor extension cord marked "W-A" or "W".** These cords are rated for outdoor use and reduce the risk of electrical shock.
- **Use only three-wire extension cords which have three-prong grounding plugs and three-pole receptacles which accept the tool's plug.** Use of other extension cords will not ground the tool and increase the risk of electrical shock.
- **Use proper extension cords.** (See chart.) Insufficient conductor size will cause excessive voltage drop and loss of power.

Minimum Wire Gauge for Extension Cord			
Nameplate Amps	Total Length (in feet)		
	0 – 25	26 – 50	51 – 100
0 – 6	18 AWG	16 AWG	16 AWG
6 – 10	18 AWG	16 AWG	14 AWG
10 – 12	16 AWG	16 AWG	14 AWG
12 – 16	14 AWG	12 AWG	NOT RECOMMENDED

- **Keep all electric connections dry and off the ground. Do not touch plugs or tool with wet hands.** Reduces the risk of electrical shock.

Personal Safety

- **Stay alert, watch what you are doing and use common sense when operating a power tool. Do not use tool while tired or under the influence of drugs, alcohol, or medications.** A moment of inattention while operating power tools may result in serious personal injury.
- **Dress properly. Do not wear loose clothing or jewelry. Contain long hair. Keep your hair, clothing, and gloves away from moving parts.** Loose clothes, jewelry, or long hair can be caught in moving parts.
- **Avoid accidental starting. Be sure switch is OFF before plugging in.** Carrying tools with your finger on the switch or plugging in tools that have the switch ON invites accidents.
- **Remove adjusting keys before turning the tool ON.** A wrench or a key that is left attached to a rotating part of the tool may result in personal injury.
- **Do not overreach. Keep proper footing and bal-**

ance at all times. Proper footing and balance enables better control of the tool in unexpected situations.

- **Use safety equipment. Always wear eye protection.** Dust mask, non-skid safety shoes, hard hat, or hearing protection must be used for appropriate conditions.

Tool Use and Care

- **Do not use tool if switch does not turn it ON or OFF.** Any tool that cannot be controlled with the switch is dangerous and must be repaired.
- **Disconnect the plug from the power source before making any adjustments, changing accessories, or storing the tool.** Such preventive safety measures reduce the risk of starting the tool accidentally.
- **Store idle tools out of the reach of children and other untrained persons.** Tools are dangerous in the hands of untrained users.
- **Check for misalignment or binding of moving parts, breakage of parts, and any other condition that may affect the tool's operation. If damaged, have the tool serviced before using.** Many accidents are caused by poorly maintained tools.
- **Use only accessories that are recommended for your tool.** Accessories that may be suitable for one tool may become hazardous when used on another tool.
- **Keep handles dry and clean; free from oil and grease.** Allows for better control of the tool.

Service

- **Tool service must be performed only by qualified repair personnel.** Service or maintenance performed by unqualified repair personnel could result in injury.
- **When servicing a tool, use only identical replacement parts. Follow instructions in the Maintenance Section of this manual.** Use of unauthorized parts or failure to follow maintenance instructions may create a risk of electrical shock or injury.

Specific Safety Information

▲ WARNING

Read this operator's manual carefully before using the 300 Power Driver. Failure to understand and follow the contents of this manual may result in electrical shock, fire and/or serious personal injury.

Call the Ridge Tool Company, Technical Service Department at (800) 519-3456 if you have any questions.

▲ WARNING Foot Switch Safety

Using a power drive or threading machine without a foot switch increases the risk of serious injury. A foot switch provides better control by letting you shut off the motor by removing your foot. If clothing should become caught in the machine, it will continue to wind up, pulling you into the machine. Because the machine has high torque, the clothing itself can bind around your arm or other body parts with enough force to crush or break bones.

Machine Safety

- **Power Drive is made to thread and cut pipe or bolt and to power RIDGID roll grooving equipment. Follow instructions on proper use of this machine. Do not use for other purposes such as drilling holes or turning winches.** Other uses or modifying this power drive for other applications may increase the risk of serious injury.
- **Secure machine to bench or stand. Support long heavy pipe with pipe supports.** This practice will prevent tipping.
- **Do not wear gloves or loose clothing when operating machine. Keep sleeves and jackets buttoned. Do not reach across the machine or pipe.** Clothing can be caught by the pipe or machine resulting in entanglement and serious injury.
- **Operate machine from side with REV/OFF/FOR switch.** Eliminates need to reach over the machine.
- **Do not use this machine if the foot switch is broken or missing.** Foot switch is a safety device to prevent serious injury.
- **Keep hands away from rotating pipe and fittings. Stop the machine before wiping pipe threads or screwing on fittings. Allow the machine to come to a complete stop before touching the pipe or machine chucks.** This practice will prevent entanglement and serious injury.
- **Do not use this machine to make or break fittings.** This practice is not an intended use of the machine and can result in serious injury.
- **Tighten chuck handwheel and engage rear centering device on the pipe before turning on the machine.** Prevents oscillation of the pipe.
- **Keep covers in place. Do not operate the machine with covers removed.** Exposure to moving parts may result in entanglement and serious injury.
- **Lock foot switch when machine is not in use (Figure 1).** Avoids accidental starting.

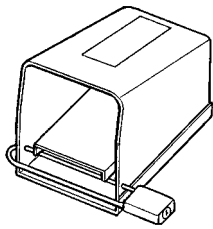

Figure 1 – Locked Foot Switch

Description, Specifications and Standard Equipment

Description

The RIDGID Model 300 Power Drive is an electric motor-driven machine which centers and chucks pipe, conduit and rod (bolt stock) and rotates it while threading, cutting and reaming operations are performed. Forward (clockwise) or Reverse (counterclockwise) rotation can be selected with the FOR/OFF/REV switch and a foot switch provides ON/OFF control of the motor.

The threading, cutting and reaming operations can be performed by conventional hand tools or tools designed for mounting on the Power Drive. A manual oiling system is available to flood the workpiece with thread cutting oil during the threading operation. Geared Threaders can also be used with the Power Drive to thread larger diameter pipe.

The RIDGID Model 300 Power Drive can also be used as a power source for roll grooving equipment. Designed to attach to the support arms of the Power Drive, the roll grooving equipment forms standard roll grooves on a variety of pipe sizes and materials.

NOTE! Contact a RIDGID distributor or consult the RIDGID catalog for specifications on roll grooving equipment.

Specifications

Threading Capacity	Pipe 1/8" through 2" Bolt 1/4" through 2"
	Geared Threaders: Pipe 2 1/2" through 6"
Chuck	Speed Grip Chuck with Replaceable Jaw Inserts
Rear Centering Device....	Cam Action Rotates with Chuck
Operating Speed	38 RPM or 57 RPM
Motor:	
Type	Universal
Horsepower.....	1/2 HP

Volts	120V Single Phase AC 25-60 Hz (230V Available On Request)
Amps	15 Amps (36 RPM) 18 Amps (57 RPM)
Controls	FOR/OFF/REV Switch and ON/OFF Foot Switch
Weight.....	77 lbs.

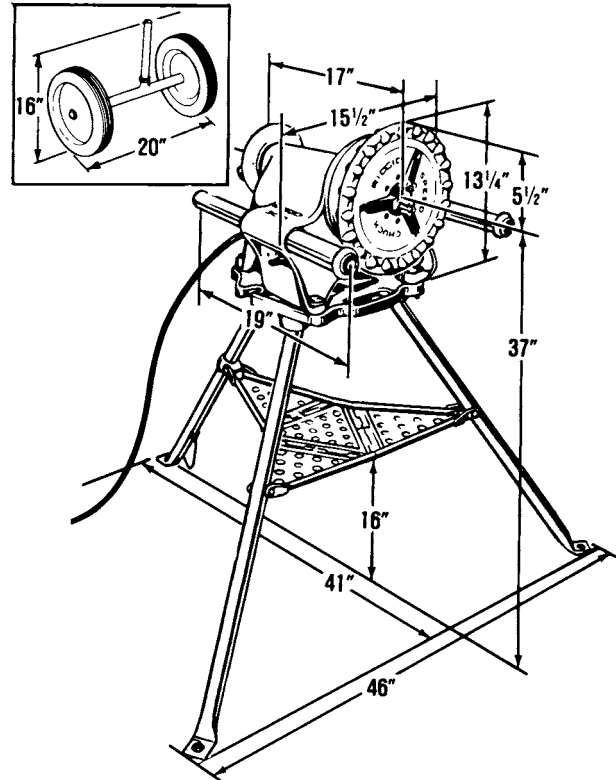

Figure 2 – No. 300 Power Drive and No. 1206 Stand

Standard Equipment

Power Drive Only:

- 300 Power Drive

Power Drive Complete:

- 300 Power Drive
- 1206 Stand
- 311 Carriage with Lever
- 341 Reamer
- 360 Cutter
- 811A Universal Die Head
- Set 1/2" – 3/4" Universal Alloy Dies
- Set 1" – 2" Universal Alloy Dies
- 4 oz. Can White Sealant w/ Teflon®

- 418 Oiler
- 1 Gallon Nu-Clear Thread Cutting Oil
- 32 Transporter

Catalog No.	Model No.	Description	Spindle Speed RPM	Weight	
				Lb.	Kg.
41855	300 Only	115V,25-60 Hz	38	94	43.0
75075	300 Only	115V,25-60 Hz	57	94	43.0
41860	300 Only	230V,25-60 Hz	38	94	43.0
75435	300 Only	230V,25-60 Hz	38	94	43.0
15682	300 Complete	115V,25-60 Hz 1/2" – 2" NPT	38	212	96.2
15722	300 Complete	115V,25-60 Hz 1/2" – 2" NPT	57	212	96.2

Machine Assembly

▲ WARNING



To prevent serious injury, proper assembly of the Power Drive is required. Failure to mount the Power Drive to a stable stand or bench may result in tipping and serious injury. The following procedures should be followed:

Mounting on No. 1206 Stand

1. Set up the 1206 Stand by opening legs and pushing down on the tray. Legs should be stiff and the stand should not wobble.

NOTE! The trisland leg stiffness can be increased or decreased by the following procedure:

- Place stand upside down on a flat surface.
- Unlock tray so legs are loose.
- Locate the set screw on the tray leg support on the rear leg (*Figure 3*).
- Loosen the set screw to make the adjustment. To increase stiffness, move the tray leg support up towards the base. To decrease stiffness, move the tray leg down towards the feet.
- Tighten the set screw (increasing leg stiffness increases tray tension).

2. Mount power drive on the stand using bolts and wing nuts (*Figure 3*).

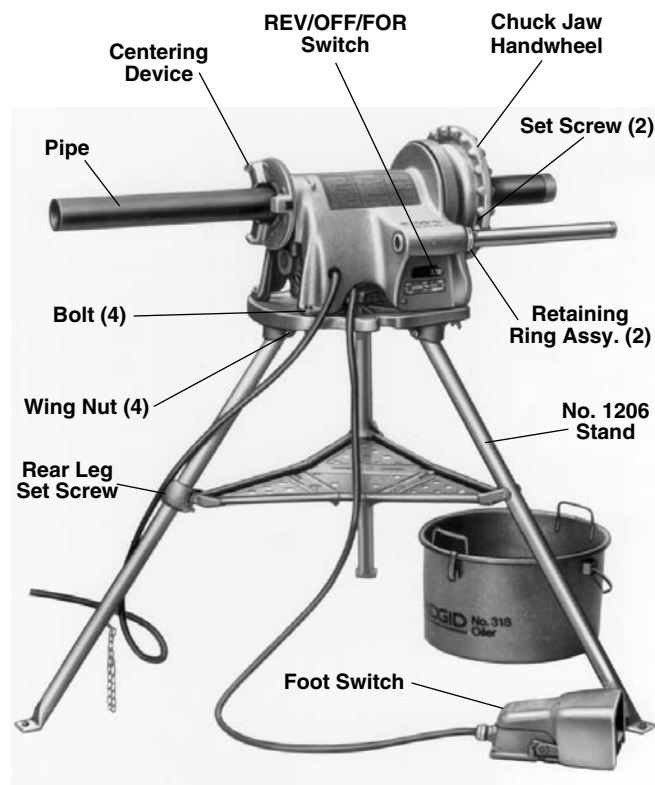

Figure 3 – 300 Power Drive Mounted on No. 1206 Stand with 418 Oiler

Mounting 311A Carriage and Tools

1. Inspect the support bars to insure they are forward and secured by two (2) retaining ring assemblies. Retaining ring set screws must be tight (*Figure 4*).

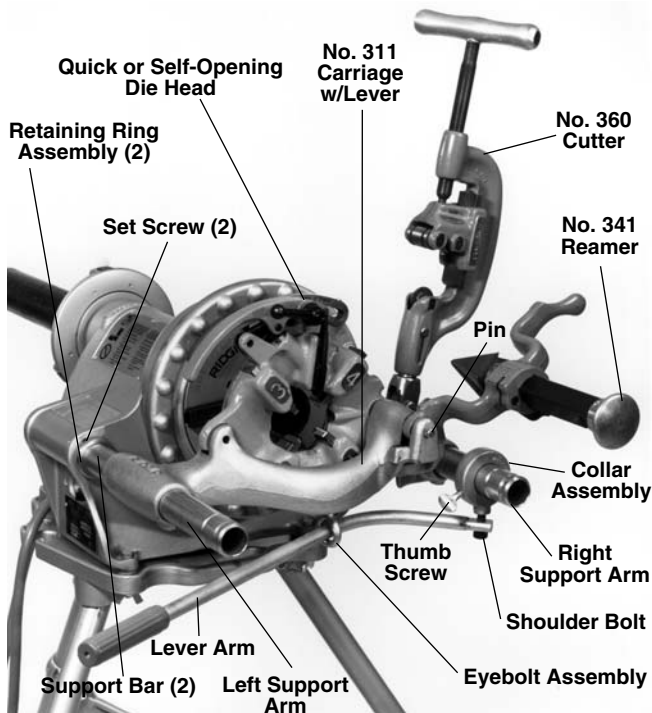

Figure 4 – No. 300 Power Drive with 311A Carriage, 360 Cutter, 341 Reamer and Die Head

2. Secure eyebolt to the 311A Carriage. Slide lever arm through the eyebolt assembly and secure to collar assembly with shoulder bolt (Figure 4).
3. Tighten collar assembly thumb screw into groove on support bar.
4. Install the 360 Cutter and 341 Reamer by inserting arm in the slot provided in the carriage and secure with the drive pin (Figure 4).
5. Install 811A Die Head by inserting die head post into the mating hole in the carriage.

NOTE! When fully inserted, spring-loaded ball will hold die head in place.

Machine Inspection

▲ WARNING

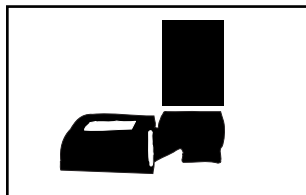

To prevent serious injury, inspect your Power Drive. The following inspection procedures should be performed on a daily basis:

1. Make sure Power Drive is unplugged and the directional switch is set to the OFF position (Figure 3).
2. Clean the speed chuck jaws with a wire brush.
3. Inspect the jaw inserts for excessive wear. Refer to the Maintenance Instructions if they need to be replaced.

NOTE! For plastic and coated work pieces, special jaw inserts (Part No. 97365) should be used to prevent damaging the workpiece.

4. Make sure the foot switch is present and attached to the Power Drive (Figure 3).

▲ WARNING Do not operate the Power Drive without a foot switch.

5. Inspect the power cord and plug for damage. If the plug has been modified, is missing the grounding pin or if the cord is damaged, do not use the Power Drive until the cord has been replaced.
6. Inspect the Power Drive for any broken, missing, misaligned or binding parts as well as any other conditions which may affect the safe and normal operation of the machine. If any of these conditions are present, do not use the Power Drive until any problem has been repaired.
7. Lubricate the Power Drive spindle bearings if necessary according to the Maintenance Instructions.
8. Use tools and accessories that are specifically designed for your Power Drive and meet the needs of your application. The correct tools and accessories allow you to do the job successfully and safely. Accessories suitable for use with other equipment may be hazardous when used with this Power Drive.
9. Clean any oil, grease or dirt from all handles and controls. This reduces the risk of injury due to a tool or control slipping from your grip.

Inspect the cutting edges of your tools and dies. If necessary, have them replaced prior to using the Power Drive. Dull or damaged cutting tools and dies can lead to binding, tool breakage and poor quality threads.

10. Clean metal shavings and other debris from the chip tray of the 418 Oiler. Check the level and quality of the thread cutting oil. Replace or add oil if necessary.

NOTE! Thread cutting oil lubricates and cools the threads during the threading operation. A dirty or poor grade cutting oil can result in poor thread quality.

Machine and Work Area Set-Up

▲ WARNING

To prevent serious injury, proper set-up of the machine and work area is required. The following procedures should be followed to set-up the machine:

1. Locate a work area that has the following:
 - Adequate lighting.
 - No flammable liquids, vapors or dust that may ignite.
 - Grounded electrical outlet.
 - Clear path to the electrical outlet that does not contain any sources of heat or oil, sharp edges or moving parts that may damage electrical cord.
 - Dry place for machine and operator. Do not use the machine while standing in water.
 - Level ground.
2. Clean up the work area prior to setting up any equipment. Always wipe up any oil that may have splashed or dripped from the machine or oiler to prevent slips and falls.
3. Set up the Power Drive on a flat, level surface.
 - For a Power Drive mounted on a 1206 Stand, open legs of stand and push down on the tray. Legs should be stiff and stand should not wobble.

NOTE! To increase or decrease leg stiffness, refer to instructions on “Mounting On 1206 Stand”.

4. If the workpiece extends more than four (4) feet beyond the Power Drive, use one or more pipe stands to prevent tipping and the oscillation of the pipe.
5. If the workpiece extends beyond the Power Drive, set-up guards or barricades to create a minimum of three (3) feet of clearance around the Power Drive and workpiece. This “safety zone” prevents others from accidentally contacting the machine or workpiece and either causing the equipment to tip or becoming entangled in the rotating parts.
6. If necessary, fill the 418 Oiler with RIDGID Thread Cutting Oil. Position the oiler under the front of the Power Drive (*Figure 3*).
7. Make sure FOR/OFF/REV switch is in the OFF position.
8. Position the foot switch so that the operator can safely control the machine, tools and workpiece. As shown in *Figure 8*, it should allow the operator to do the following:

- Stand facing the directional switch.
- Use the foot switch with his left foot.
- Have convenient access to the directional switch, tools and chucks without reaching across the machine.

Machine is designed for one person operation.

9. Plug the Power Drive into the electrical outlet making sure to position the power cord along the clear path selected earlier. If the power cord does not reach the outlet, use an extension cord in good condition.

▲ WARNING

To avoid electrical shock and electrical fires, never use an extension cord that is damaged or does not meet the following requirements:

- The cord has a three-prong plug similar to shown in Electrical Safety section.
- The cord is rated as “W” or “W-A” if being used outdoors.
- The cord has sufficient wire thickness (14 AWG below 25’/12 AWG 25’ - 50’). If the wire thickness is too small, the cord may overheat, melting the cord’s insulation or causing nearby objects to ignite.

▲ WARNING To reduce risk of electrical shock, keep all electrical connections dry and off the ground. Do not touch plug with wet hands.

10. Check the Power Drive to insure it is operating properly.
 - Flip the directional switch to FOR (Forward). Press and release the foot switch. Check that the Power Drive rotates in a counterclockwise direction as you are facing the front chuck. Have the Power Drive serviced if it rotates in the wrong direction or if the foot switch does not control its stopping or starting.
 - Depress and hold the foot switch. Inspect the moving parts for misalignment, binding, odd noises or any other unusual conditions that may affect the safe and normal operation of the machine. If such conditions are present, have the power drive serviced.
 - Flip the directional switch to REV (Reverse). Press and release the foot switch. Check that the Power Drive rotates in a clockwise direction as you are facing the chuck.
 - Release the foot switch and flip the directional switch to OFF.

Operating Instructions For Using Hand Tools

⚠ WARNING

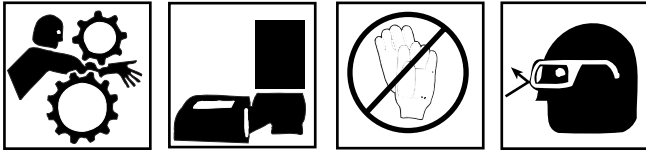

Do not wear gloves or loose clothing when operating Power Drive. Keep sleeves and jackets buttoned. Do not reach across the machine or pipe.

Do not use this Power Drive if the foot switch is broken or missing. Always wear eye protection to protect eyes from dirt and other foreign objects.

Keep hands away from rotating pipe and fittings. Stop the machine before wiping pipe threads or screwing on fittings. Allow the machine to come to a complete stop before touching the pipe or machine chucks.

Do not use this machine to “make-on” or “break off” fittings. This practice is not an intended use of this Power Drive.

Installing Pipe In Power Drive:

1. Mark the pipe at the desired length if it is being cut to length.
2. Insert the pipe into the Power Drive so that the end to be worked or the cutting mark is located about 12 inches to the front of the speed chuck jaws.
3. Insert workpieces less than 2 feet long from the front of the machine. Insert longer pipes through either end so that the longer section extends out beyond the rear of the Power Drive.

⚠ WARNING To avoid equipment tip-overs, position the pipe supports under the workpiece.

4. Tighten the rear centering device around the pipe by using a counterclockwise rotation of the handwheel at the rear of the Power Drive. This prevents movement of the pipe that can result in poor thread quality.
5. Secure the pipe by using repeated and forceful counterclockwise spins of the speed chuck handwheel at the front of the Power Drive. This action “hammers” the jaws tightly around the pipe.
6. Extend both support bars fully beyond the front of the Power Drive.

Cutting Pipe with Hand Cutter

1. Position the pipe cutter on the workpiece with the cutter wheels facing up (see “Accessories” section for pipe cutters recommended for use with this Power Drive).
2. Align the cutter wheels with the mark on the pipe and rest the pipe cutter’s body on the left support bar (*Figure 5*). Hand-tighten the pipe cutter to the workpiece using the feedscrew handle while keeping the cutter wheels aligned with the mark.
3. Assume the correct operating posture (*Figure 8*). This will allow you to maintain proper balance and to safely keep control of the machine and tools.
 - Be sure you can quickly remove your foot from the foot switch.
 - Stand facing the directional switch.
 - Be sure you have convenient access to directional switch, tools and chucks.
 - Do not reach across the machine or workpiece.
4. Flip the directional switch to FOR (Forward).
5. Grasp the pipe cutter’s feedscrew handle with both hands (*Figure 5*) and depress and hold down the foot switch with the left foot.

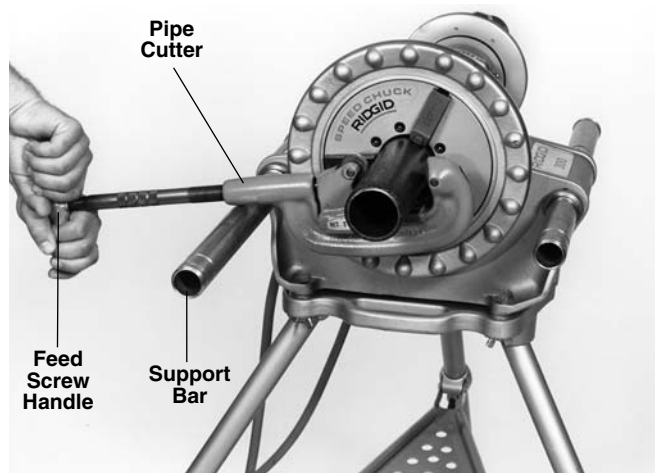

Figure 5 – Cutting Pipe with Hand Cutter

6. Tighten the feedscrew handle slowly and continuously until the pipe is cut. Do not force the cutter into the workpiece.

⚠ WARNING To avoid impact injuries, keep a firm grip on the pipe cutter and be sure it is resting on the support bar. If not held firmly or supported, the tool may rotate or fall to the ground.

7. Release the foot switch and remove your foot from the housing.

Reaming Pipe with Hand Reamer

⚠ WARNING To prevent serious injury, do not use self-feeding spiral reamers with the 300 Power Drive.

1. Flip the directional switch to FOR (Forward).
2. Place the reamer in the end of the pipe (see the “Accessories” section for reamers recommended for use with this Power Drive).
3. Assume the correct operating posture.
4. Rest handle on the left support bar (*Figure 6*) and hold the reamer handgrip with the right hand. To avoid pinch point injuries, keep your fingers from coming between the reamer and the support bar.
5. Firmly grasp the end of the reamer handle with the left hand, then depress and hold the foot switch down.
6. Push the reamer firmly into the pipe with your right hand until ream is complete. Keep your hand and arm away from any rotating parts and use a firm grip on the handgrip.
7. Release the foot switch and remove your foot from the housing while holding the reamer with both hands.

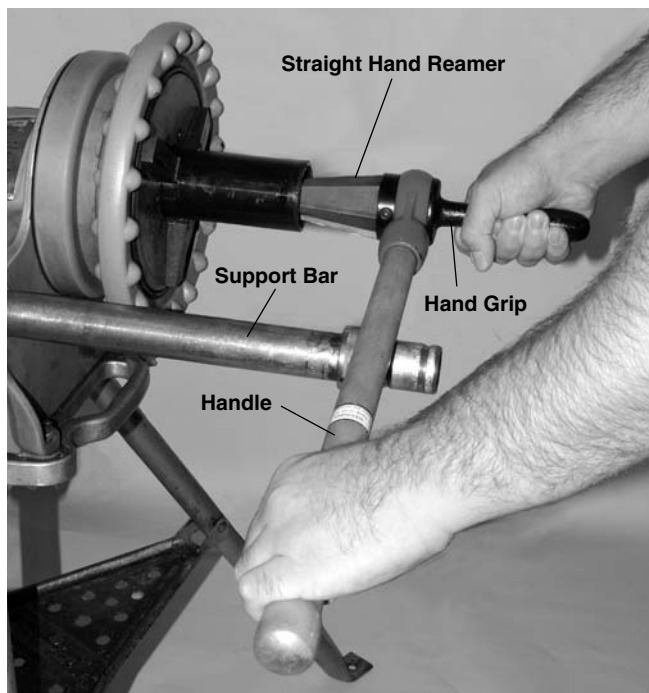

Figure 6 – Reaming Pipe with Hand Reamer

8. Remove the reamer from the workpiece once the Power Drive has stopped rotating.

Threading Pipe with Hand Threader

1. Place the die head of the hand threader on the end of the pipe (see “Accessories” section for hand threaders recommended for use with this Power Drive).
2. Position the ratchet knob on the hand threader so that the arrow on the knob points up.
3. Rest the hand threader ratchet handle on the left support bar (as viewed when facing the front of the Power Drive – *Figure 7*).

⚠ WARNING To avoid pinch point injuries, keep your fingers from coming between the hand threader and the support bar.

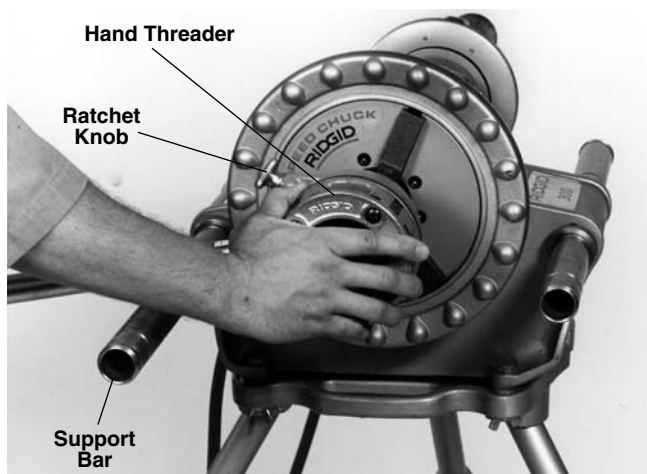

Figure 7 – Pushing Hand Threader onto Pipe to Engage Dies

4. Apply RIDGID Thread Cutting Oil to the end of the pipe.
5. Assume the correct operating posture. Check to ensure directional switch is in the FOR (Forward) position.
6. Hold the die head against the workpiece with the right hand.

⚠ WARNING To avoid injury from rotating parts or sharp surfaces, keep hands and fingers away from anything other than the outer body of the die head.

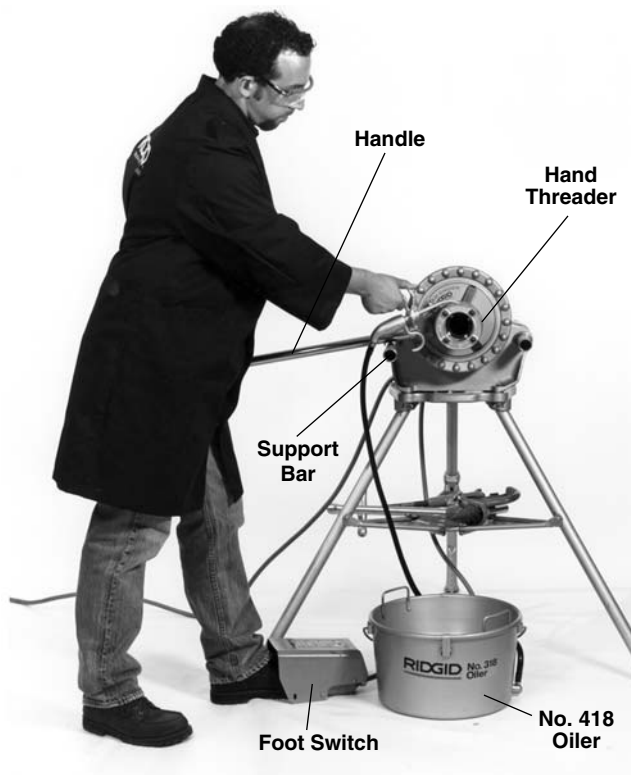

Figure 8 – Threading with Hand Threader

7. Depress and hold down the foot switch.
 8. Push the die head against the pipe using the palm of the right hand until the dies engage the workpiece. Once engaged, the threads will be cut as the dies pull themselves onto the end of the pipe (*Figure 7*).
 9. Remove the right hand from the area of the die head and liberally oil the dies while the pipe is threaded (*Figure 8*).
- ▲ WARNING** To avoid serious injury from rotating parts, allow adequate clearance between your hand and the rotating parts while oiling.
10. Release the foot switch and remove your foot from the housing when the pipe reaches the end of the dies.
 11. Lift the threader handle slightly with the right hand while sliding the left support bar all the way toward the rear of the drive.

12. Reverse the ratchet knob. The arrow on the knob should point down.
 13. Lower the threader handle below the height of the left support bar.
 14. Slide the left support bar back to its fully extended position in front of the Power Drive.
 15. Lift and hold the threader handle against the left support bar.
 16. Flip the directional switch to REV (Reverse). Depress and hold the foot switch down until the threader has unscrewed itself from the workpiece.
- ▲ WARNING** To avoid injury due to falling parts, maintain a firm grip on the threader as the threader will drop to the floor if not supported when unthreaded completely.
17. Release the foot switch and remove your foot from the housing.
 18. Set the threader down and, if necessary, wipe oil and debris off the threads with a rag, taking care not to cut your hand or fingers on any sharp debris or edges.
 19. Check the thread for length and depth (*Figure 14*).

Removing Pipe from the Power Drive

1. Flip the directional switch to OFF.
 2. Use repeated and forceful clockwise spins of the speed chuck handwheel at the front of the Power Drive to release the workpiece from the speed chuck jaws.
 3. If necessary, loosen the rear centering device using a clockwise rotation of the handwheel at the rear of the Power Drive.
 4. Slide the workpiece out of the Power Drive, keeping a firm grip on the workpiece as it clears the Power Drive.
- ▲ WARNING** To avoid injury from falling parts or equipment tip-overs when handling long workpieces, make sure that the end farthest from the Power Drive is supported prior to removal.
5. Clean up any oil spills or splatter on the ground surrounding the Power Drive.

Operating Instructions for Carriage-Mounted Power Drive Tools

⚠ WARNING

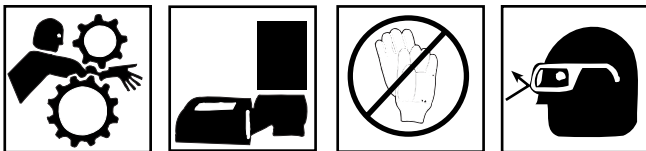

Do not wear gloves or loose clothing when operating Power Drive. Keep sleeves and jackets buttoned. Do not reach across the machine or pipe.

Do not use this Power Drive if the foot switch is broken or missing. Always wear eye protection to protect eyes from dirt and other foreign objects.

Keep hands away from rotating pipe and fittings. Stop the machine before wiping pipe threads or screwing on fittings. Allow the machine to come to a complete stop before touching the pipe or machine chucks.

Do not use this machine to “make-on” or “break off” fittings. This practice is not an intended use of this Power Drive.

Installing Pipe in Power Drive

1. Check to insure the cutter, reamer and die head is swung to the rear of the carriage.
2. Mark the pipe at the desired length if it is being cut to length.
3. Insert the pipe into the Power Drive so that the end to be worked or the cutting mark is located about 12 inches to the front of the speed chuck jaws.
4. Insert workpieces less than 2 feet long from the front of the machine. Insert longer pipes through either end so that the longer section extends out beyond the rear of the Power Drive.

⚠ WARNING To avoid equipment tip-overs, position the pipe supports under the workpiece.

5. Tighten the rear centering device around the pipe by using a counterclockwise rotation of the handwheel at the rear of the Power Drive. This prevents movement of the pipe that can result in poor thread quality.
6. Secure the pipe by using repeated and forceful counterclockwise spins of the speed chuck handwheel at the front of the Power Drive. This action “hammers” the jaws tightly around the pipe.

Cutting Pipe with No. 360 Cutter

1. Check to insure the reamer and die head are in the UP position (*Figure 9*).

2. Move pipe cutter down onto pipe and move carriage with carriage lever to line up cutter wheel with mark on pipe.
3. Tighten cutter feedscrew handle while keeping the cutter wheel aligned with the mark.
4. Assume the correct operating posture (*Figure 11*).

⚠ WARNING This will allow you to maintain proper balance and to safely keep control of the machine and tools.

- Be sure you can quickly remove your foot from the foot switch.
 - Stand facing the directional switch.
 - Be sure you have convenient access to directional switch, tools and chucks.
 - Do not reach across the machine or workpiece.
5. Flip the directional switch to FOR (Forward).
 6. Grasp the pipe cutter’s feed handle with both hands (*Figure 9*).

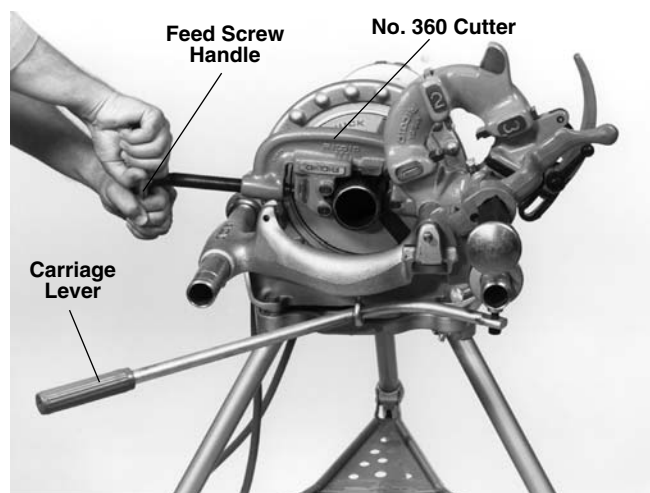

Figure 9 – Cutting Pipe with No. 360 Cutter

7. Depress and hold down the foot switch with the left foot.
8. Tighten the feedscrew handle slowly and continuously until the pipe is cut. Do not force the cutter into the workpiece.
9. Release the foot switch and remove your foot from the housing.
10. Swing pipe cutter back to the UP position.

Reaming Pipe with No. 341 Reamer

1. Move reamer arm down into reaming position (*Figure 10*).

2. Extend reamer by pressing latch and sliding knob toward pipe until latch engages.
3. Check the directional switch to insure it is in the FOR (Forward) position. Depress and hold the foot switch down with the left foot.
4. Position reamer into pipe and complete reaming by pushing carriage lever with right hand.
5. Retract reamer bar and return reamer to the UP position.

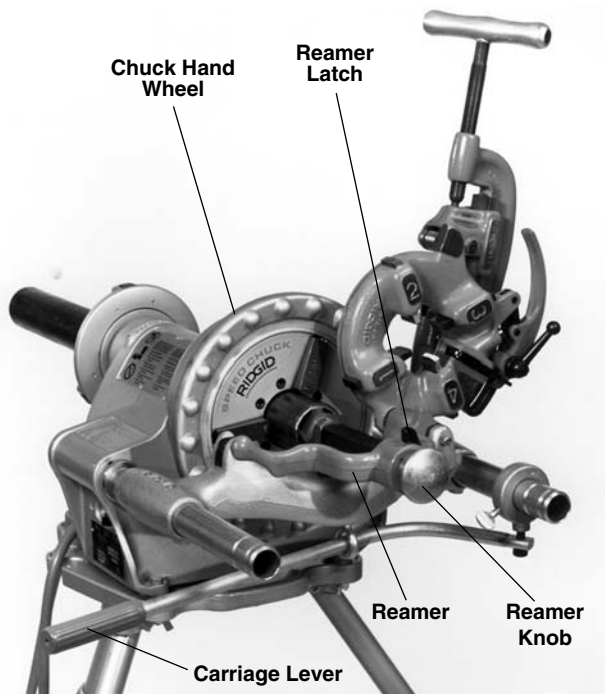

Figure 10 – Reaming Pipe with No. 341 Reamer

6. Release foot switch and remove your foot from the housing.

Threading Pipe with Quick-Opening or Self-Opening Die Head

1. Check to insure the cutter and reamer are to the rear of the carriage (*Figure 11*).
2. Lower die head into threading position.

3. Check that the proper size dies are in the die head. One set of dies is required for each of the following pipe size ranges: ($\frac{1}{8}$ "), ($\frac{1}{2}$ " – $\frac{3}{8}$ "), ($\frac{1}{2}$ " – $\frac{3}{4}$ ") and (1" – 2"). Bolt threading requires a separate set of dies for each bolt size.
4. Set die head to proper size.

NOTE! Refer to the Section on the No. 811A or No. 815A Die Head for instructions on changing dies and adjusting for proper size.

5. Quick-Opening 811A Die Head (*Figure 12*) – Rotate throwout lever to the CLOSED position.
Self-Opening 815A Die Head (*Figure 13*) – Push throwout lever down until the release trigger cocks.
6. Apply RIDGID Thread Cutting Oil to end of the pipe.
7. Assume the correct operating posture.
8. Check directional switch to insure it is in the FOR (Forward) position. Depress and hold the foot switch down with the left foot.
9. Engage dies with pipe using carriage lever and oil dies with plenty of RIDGID Thread Cutting Oil until thread is completed.

▲ WARNING To avoid serious injury from rotating parts, allow adequate clearance between your hand and rotating parts when oiling.

10. Quick-Opening 811A Die Head (*Figure 12*) – When thread is completed, raise throwout lever to open position, retracting dies.
Self-Opening 815A Die Head (*Figure 13*) – When die head trigger contacts end of pipe, throwout lever automatically opens.
11. Release foot switch and remove your foot from the housing.
12. Move carriage lever away from pipe end and return die head to the UP position.
13. Check the thread for length and depth (*Figure 14*).

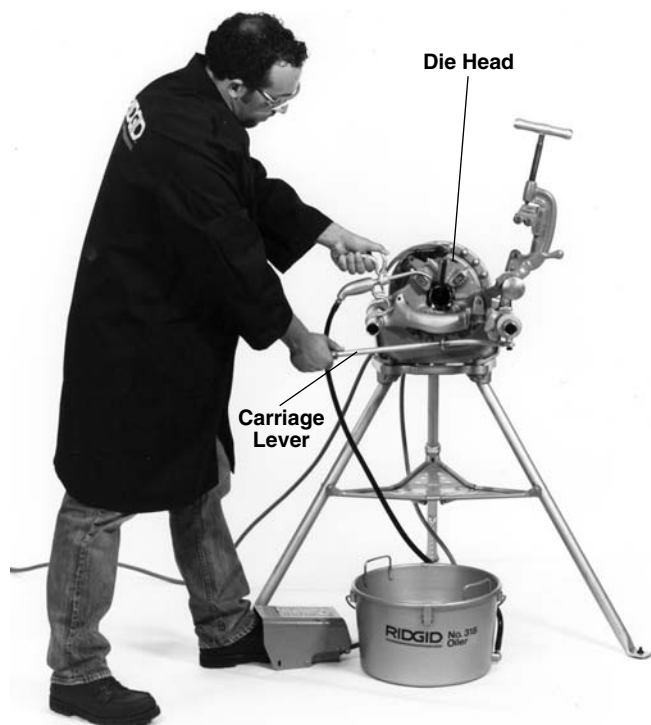

Figure 11 – Threading Pipe with Quick or Self-Opening Die Head

Removing Pipe from the Power Drive

1. Flip directional switch to OFF.
2. Use repeated and forceful clockwise spins of the speed chuck handwheel at the front of the Power Drive to release the workpiece from the speed chuck jaws.
3. If necessary, loosen the rear centering device using a clockwise rotation of the handwheel at the rear of the Power Drive.
4. Slide the workpiece out of the Power Drive, keeping a firm grip on the workpiece as it clears the Power Drive.

▲ WARNING To avoid injury from falling parts or equipment tip-overs when handling long workpieces, make sure that the end farthest from the Power Drive is supported prior to removal.

5. Clean up any spills or splatter on the ground surrounding the Power Drive.

Installing Dies in No. 811A Quick-Opening Die Head (Right and Left Hand)

NOTE! The No. 811A Universal Die Head (Figure 12) for right hand threads requires four sets of dies for thread pipe ranging from $\frac{1}{8}$ " through 2". One set of dies is required for each of the following pipe

size ranges: ($\frac{1}{8}$ "), ($\frac{1}{4}$ " – $\frac{3}{8}$ "), ($\frac{1}{2}$ " – $\frac{3}{4}$ " and (1" – 2"). The $\frac{1}{8}$ " pipe dies are not available for left hand die head. Bolt threading requires a separate set of dies for each bolt size. No bolt dies are available for left hand universal die heads.

1. With machine unplugged, remove die head. Lay die head on bench with numbers face up.
2. Flip throwout lever to OPEN position.
3. Loosen clamp lever approximately three turns.
4. Lift tongue of clamp lever washer up and out of slot under size bar. Slide throwout lever all the way to end of slot in the OVER direction indicated on size bar (in direction of CHANGE DIES arrow on rear of cam plate).
5. Remove dies from die head.
6. Insert new dies to mark on side of dies. Die numbers 1 through 4 on the dies must agree with those on die head.
7. Slide throwout lever back so that tongue of clamp lever washer will drop in slot under size bar.
8. Adjust die head size bar until the index line on lock screw or link is aligned with proper size mark on size bar. For bolt threads, align index line with BOLT line on size bar.
9. Tighten clamp lever.
10. If oversize or undersize threads are required, set the index line in direction of OVER or UNDER size mark on size bar.
11. Replace die head in machine.

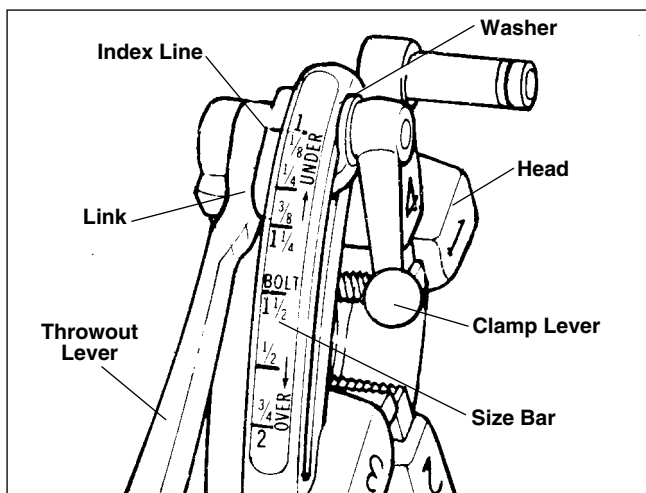

Figure 12 – Universal Quick-Opening Die Head

Installing Dies in No. 815A Self-Opening Die Head (Right Hand Only)

NOTE! The No. 815 Self-Opening Die Head (Figure 13) for right hand threads requires four sets of dies to thread pipe ranging from 1/8" through 2". One set of dies is required for each of the following pipe size ranges: (1/8"), (1/4" – 3/8"), (1/2" – 3/4") and (1" – 2"). Bolt threading requires a separate set of dies for each bolt size.

1. With machine unplugged, remove die head. Place self-opening die head on bench in vertical position.
2. Make sure trigger assembly is released.
3. Loosen clamp lever approximately six turns.
4. Pull lock screw out of slot under size bar so that roll pin in lock screw will by-pass slot. Position size bar so that index line on lock screw is all the way to the end of REMOVE DIES position.
5. Lay head down with numbers up.
6. Remove worn dies from die head.
7. Insert new dies to mark on side of dies. Die numbers 1 through 4 on the dies must agree with those on die head.
8. Rotate cam plate lever back to lock dies in head.
9. With head in vertical position, rotate cam plate until roll pin on lock screw can be positioned in slot under size bar. In this position, dies will lock in die head. Make sure roll pin points toward end of size bar marked REMOVE DIES.
10. Adjust die head size bar until index line on lock screw or links is aligned with proper size mark on size bar. For bolt threads, align index line with BOLT line on size bar.
11. Tighten clamp lever.
12. If oversize or undersize threads are required, set the index line in direction of OVER or UNDER size mark on size bar.
13. Replace die head in machine.

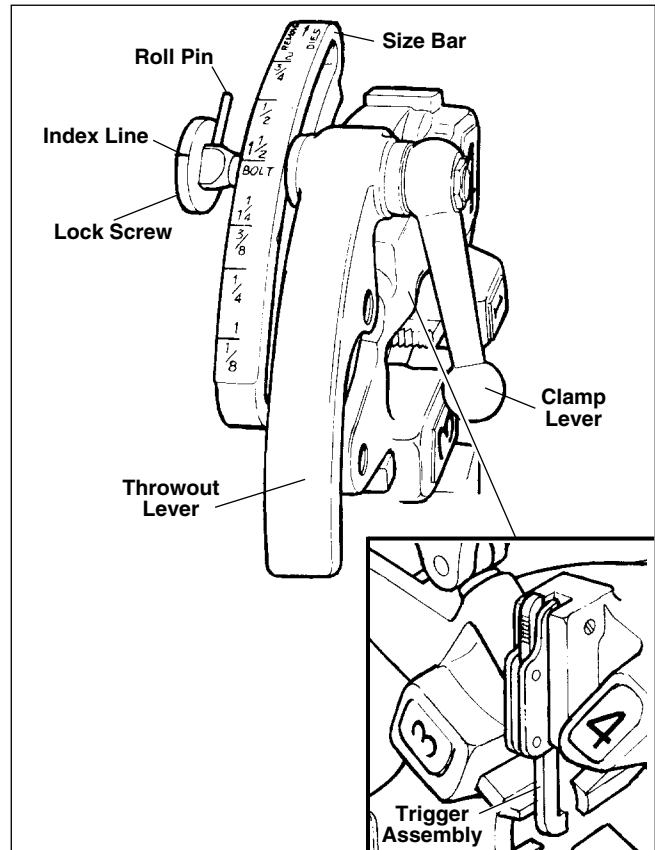

Figure 13 – No. 815 Self-Opening Die Head

Checking Thread Length

1. Thread is cut to proper length when end of pipe is flush with edge of dies (Figure 14A).
2. Die Head is adjustable to obtain proper thread diameter. If possible, threads should be checked with a thread ring gage (Figure 14B). A proper thread is cut when end of pipe is plus or minus one turn of being flush with face of ring gage.

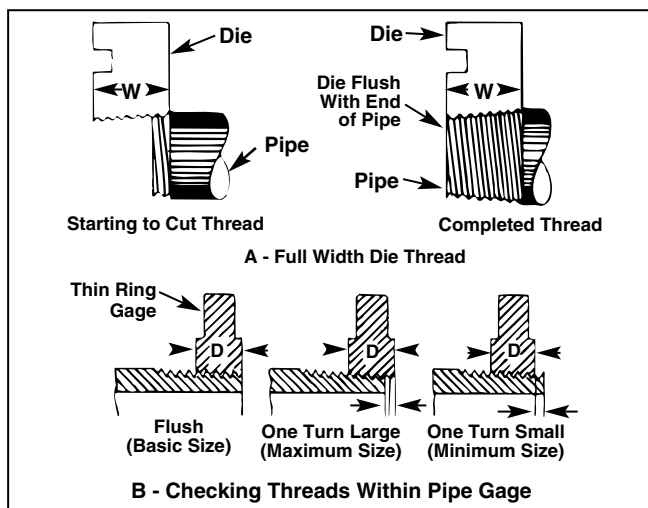
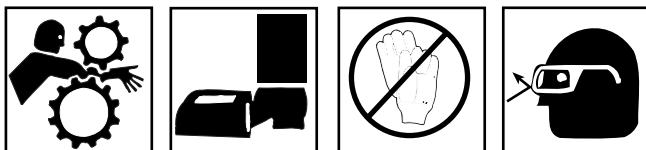

Figure 14 – Checking Thread Length

NOTE! If a ring gauge is not available, a fitting can be used. This fitting should be representative of those being used on the job. The pipe thread should be cut to obtain 2 to 3 turns hand tight engagement with fitting. If pipe thread is not proper diameter the index line should be moved in the direction of the OVER or UNDER size mark on size bar. (Refer to “Installing Dies in Die Heads”).

Operating Instructions Using Geared Threaders

⚠ WARNING



Do not wear gloves or loose clothing when operating Power Drive. Keep sleeves and jackets buttoned. Do not reach across the machine, geared threader or drive shaft.

Do not use this Power Drive if the foot switch is broken or missing. Always wear eye protection to protect eyes from dirt and other foreign objects.

To prevent tipping, proper set-up of the Threading Machine and Geared Threader is required. Follow instructions carefully.

Geared Threaders weigh 95 to 160 pounds. Two (2) persons should be used to lift these threaders.

Adjusting Nos. 141 and 161 Geared Threaders

Cam Plate (Pipe Size) Adjustment Procedure

1. Place threader on floor or workbench with drive shaft up.
2. Pull knobs (*Figure 15*) of cam plate and rotate cam plate to desired pipe size marking on top of die head. Release knobs when locating pins drop into hole in selector plate.

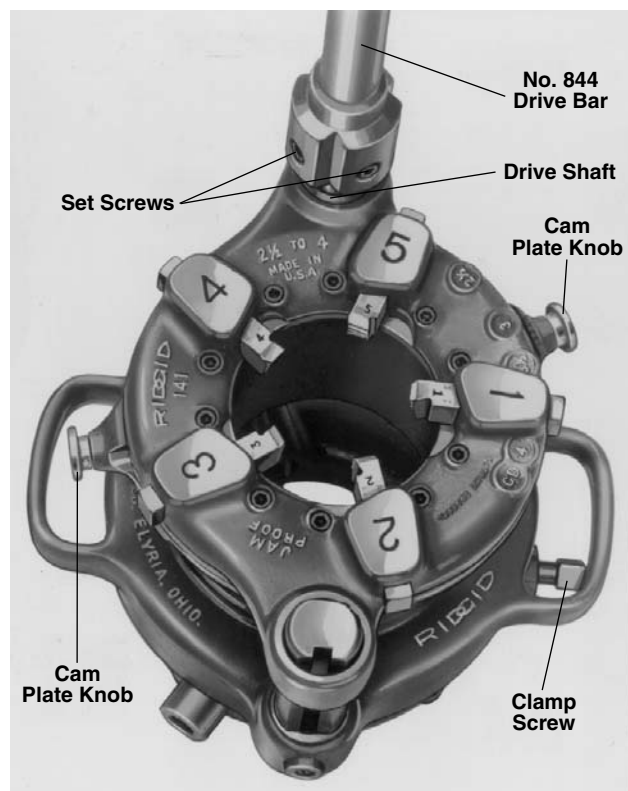

Figure 15 – No. 141 Geared Threader with No. 844 Drive Bar Installed (No. 161 Threader Similar)

Thread Size Adjustment Procedure

Grasp workholder and turn square end of drive shaft or turn gear case by hand to respective reference lines on guide post (*Figure 16*).

Standard Size Thread - Either one of the following two (2) reference lines may be used.

Reference Line 1: Set bottom surface of die head at red STANDARD line on pinion sleeve.

Reference Line 2: Set upper surface of die head which houses guide post even with STANDARD line at top end of guide post.

Oversize Thread: For oversize (shallow thread) set head at bottom line on guide post. This line is marked (2T OVER).

Undersize Thread: For undersize (deep thread) set head at top line on guide post. This line is marked (2T UNDER).

Changing Posts For Straight Or Tapered Threads

1. Adjust threader to cut standard size threads using "STANDARD" reference line.
2. Remove screw from gear case at base of guide post.

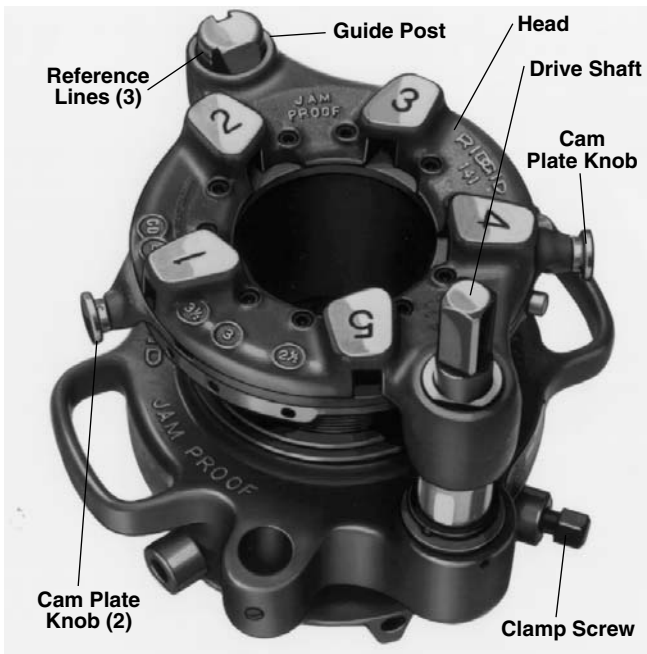

Figure 16 – No. 141 Geared Threader Showing Pinion Sleeve and Guide Post Reference Lines

3. Pull guide post up until guide block attached to selector plate is disengaged from angle slot in guide post.
4. Turn guide post until straight slot faces inward for straight thread. For tapered threads set tapered slot inward. *Figure 16* shows guide post set to cut tapered thread.
5. Engage guide block in slot and push guide post down into position.
6. Replace guide post screw.

Unit is now set to cut straight threads (NPSM or BSPP) or taper threads (NPT or BSPT).

Changing Die Set

1. Remove stop screw (*Figure 17*) from selector plate.

2. Pull Knobs (*Figure 15*) and rotate cam plate to CD mark on top of die head.

3. Remove worn die set (*Figure 15*) and insert new die set.

IMPORTANT! Be sure to replace complete die set. Die numbers must correspond with slot numbers.

4. Rotate cam plate to original position and replace stop screw.

NOTE! If it becomes necessary to remove or replace the guide block, the stamped number E-1997 on guide block must be AGAINST selector plate. If stamped number is visible you will cut an UNDERSIZE thread.

Installing Nos. 141 and 161 Geared Threaders (Close-Coupled Method)

1. Place threader on floor or workbench with drive shaft up. Install No. 844 Drive Bar on threader drive shaft and tighten two (2) set screws (*Figure 15*).

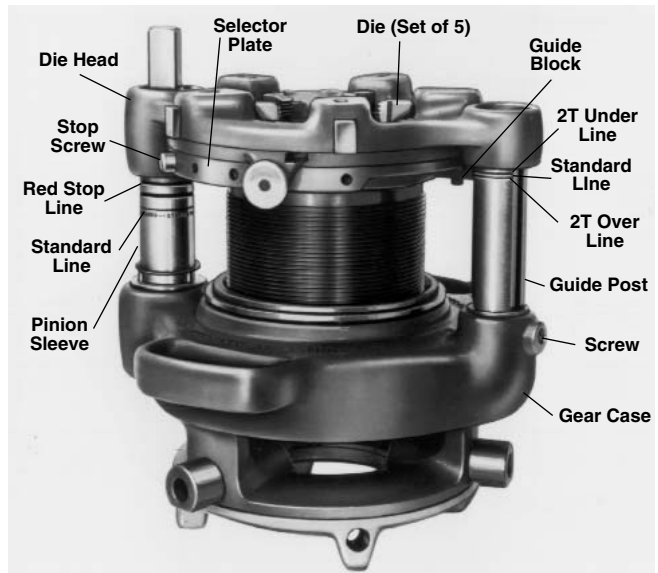

Figure 17 – No. 141 Geared Threader with 844 Drive Bar Installed (No. 161 Threader Similar)

2. Using two persons, pick up threader and insert drive bar into chuck of Power Drive. Tighten Power Drive chuck jaws into three "V" shaped grooves in head of drive bar.

IMPORTANT! Allow approximately 3/4" of V-shaped grooves exposed in front of chuck jaws (*Figure 17*) to allow space for oiling.

3. Close centering chuck on shaft of drive bar.

4. 141 Geared Threaders (Figure 19) – Pull out support bar on switch side and secure retaining ring against Power Drive body with set screws.

161 Geared Threaders (Figure 20) – Insert No. 346 Support Arms into support bars and secure retaining rings against Power Drive body with set screws.

5. 141 Geared Threaders (Figure 19) – Slip No. 758 Loop over support bar and secure to gear case loop with set screw.

NOTE! Use No. E-3675 Adapter Bracket (Figure 19) in place of No. 758 Loop on all 4P Threaders without loop hole on gear case.

161 Geared Threader (Figure 20) – Remove set screw (plug) from threader guide post and secure support arms with bolt and washer.

6. Support pipe with a pipe support (Figure 21). Position support approximately 2-1/2 feet from threader.

7. Insert pipe in threader and center end of pipe in throat of dies. Tighten workholder with socket wrench (Figure 18).

8. Tighten clamp screw securely with socket wrench.

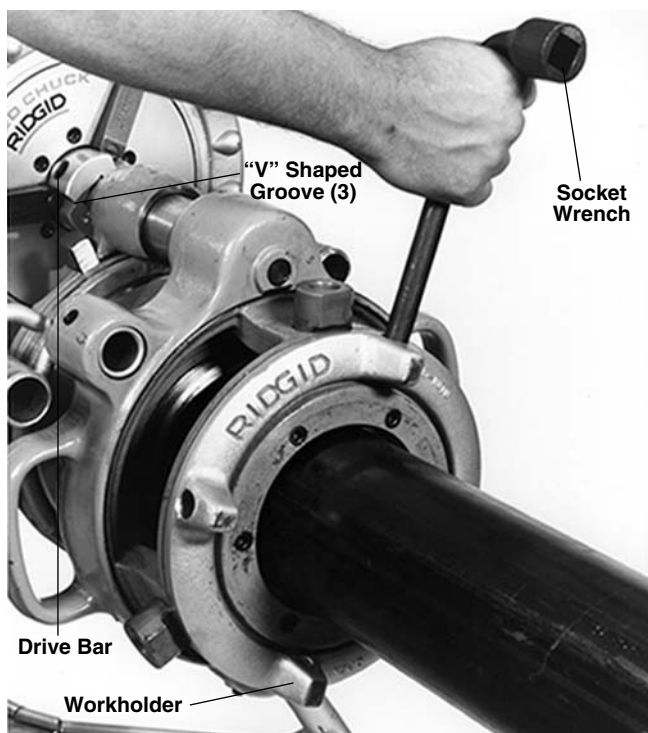

Figure 18 – Tightening Workholder on No. 141 Geared Threader (No. 161 Threader Similar)

9. Position No. 418 Oiler directly under threader (Figure 21).

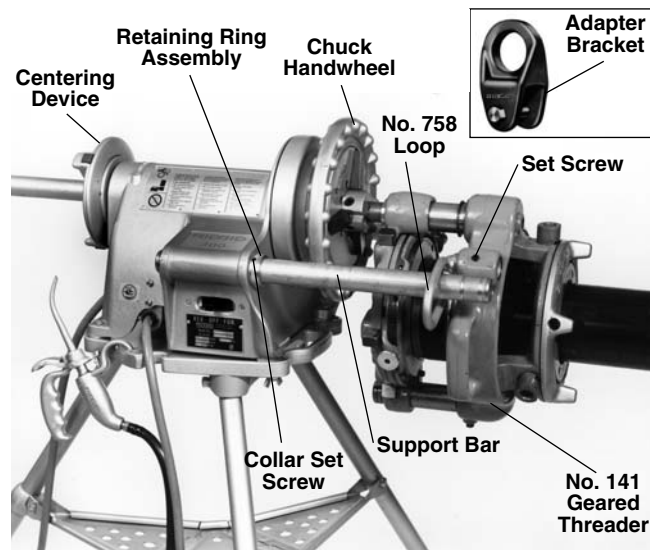

Figure 19 – No. 141 Geared Threader Close-Coupled to Power Drive

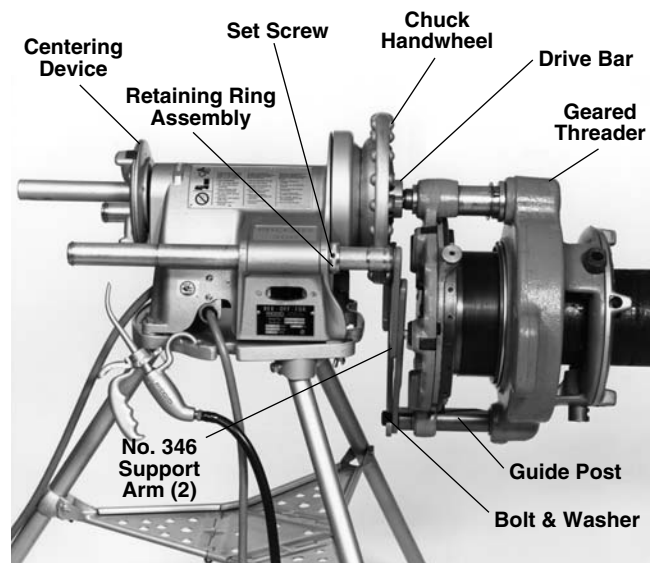

Figure 20 – No. 161 Geared Threader Close-Coupled to Power Drive

Threading using Nos. 141 and 161 Geared Threaders (Close-Coupled Method)

1. Install geared threader and pipe.
2. Turn Power Drive REV/OFF/FOR switch to FOR (Forward) position.
3. Step on foot switch.
4. Flood dies with RIDGID Thread Cutting Oil during threading operation to assure long die life.

5. 141 and 161 – Release foot switch when red STOP line appears on pinion sleeve (*Figure 17*).

NOTE! RIDGID Geared Threaders have a jam-proof design so pinion shaft will automatically disengage if threader is accidentally run on pipe past a full thread length.

6. Turn REV/OFF/FOR switch to REV (Reverse) position. Step on foot switch and back threader off of pipe.

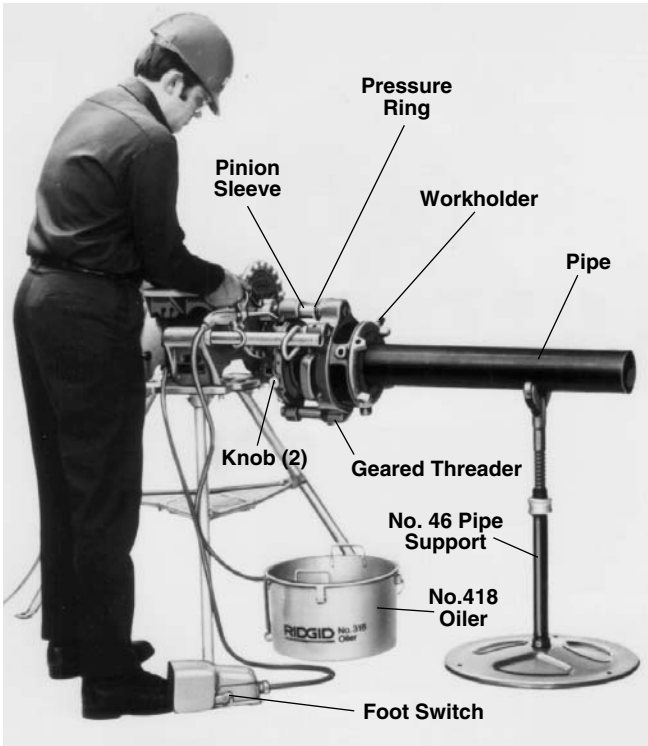

Figure 21 – Threading Pipe with No. 141 Geared Threader (Close-Coupled Method) (No. 161 Threader Similar)

IMPORTANT! Allow approximately $\frac{3}{4}$ " of V-shaped grooves exposed in front of chuck jaws (*Figure 17*) to allow space for oiling.

7. 141 and 161 – Using the socket wrench, loosen clamp screw (*Figure 16*), turn workholder to OPEN position and remove pipe.

NOTE! Before threading next piece of pipe, run threader head beyond STANDARD line on pinion sleeve and then back to STANDARD line. This movement takes up slack in gearing for immediate response when cutting next thread.

8. Turn REV/OFF/FOR switch to OFF position.

IMPORTANT! If, by accident, a RIDGID Geared Threader is backed off too far and threaded barrel becomes disengaged from workholder, the threader must be removed from the Power Drive and put on a bench. Re-engage the threads carefully by hand. Do not attempt this by power.

Installing Nos. 141 and 161 Geared Threaders Using No. 840A Universal Drive Shaft

▲ WARNING

When threading pipe larger than 2 inches, the Power drive stand must be bolted to the floor. Chain vise must be securely anchored with jacks screw assembly and post to ceiling or bolted to floor. Failure to follow these instructions could result in the Vise or Power Drive tipping and causing serious injury.

When threading pipe up to 5 inches nominal, the 450 Tristand Vise can be used. However, when threading 6 inch nominal pipe, a BC-610, BC-810 Top Screw Bench Chain Vise or a 460 Tristand Vise must be used.

1. Adjust threader being used.
2. Slide long hexagon end of the universal drive shaft into front chuck of Power Drive. Tighten chuck hand-wheel and centering chuck.
3. Locate chain vise in line, on same level, and approximately the length of universal drive shaft away from Power Drive front chuck (*Figure 22*).
4. Tightly secure pipe in No. 450 or 460 Chain Vise.
5. Support long pieces of pipe with pipe support.
6. Using two persons, position workholder so that a jaw is on top center and slide threader onto pipe. Carefully center end of pipe in throat of dies.

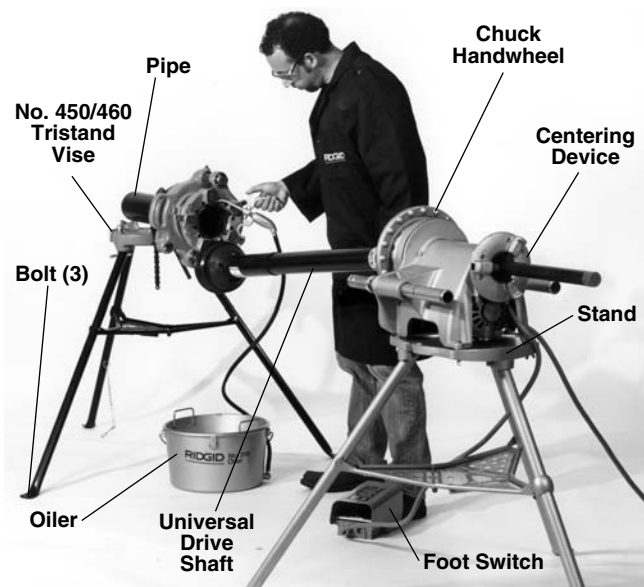

Figure 22 – Threading with Nos. 141 and 161 Geared Threaders using No. 840A Universal Drive Shaft

7. Using socket wrench, tighten workholder clamp screw (Figure 15) securely.
8. Slip square socket of No. 840A Universal Drive Shaft over square end of threader drive shaft and tighten two (2) set screws.

IMPORTANT! When properly positioned, sliding shank of universal drive shaft should be approximately centered to allow movement in either direction.

9. Position No. 418 Oiler directly under threader.

Threading Using Nos. 141 and 161 Geared Threaders with No. 840A Universal Drive Shaft

1. Follow Steps 1 through 6 of Geared Threader Operating Instructions (Close-Coupled Method).
2. Turn REV/OFF/FOR switch to OFF position.
3. Loosen two (2) set screws and remove universal drive shaft from threader.
4. 141 and 161 – Loosen jaw clamp screw (Figure 15) and turn workholder to OPEN position.
5. Loosen chain vise and remove pipe.

NOTE! If, by accident, a RIDGID Geared Threader is backed off too far and threaded barrel becomes disengaged from workholder, the threader must be removed from the Power Drive and be put on a bench. Re-engage the threads carefully by hand. Do not attempt this by power.

No. 819 Nipple Chuck

The RIDGID No. 819 Nipple Chuck is designed for holding short and close nipples or studs for threading. The No. 300 Power Drive should be equipped with 2 (two) support bars, No. 311A Carriage and self-opening or quick-opening die head.

Capacity: $\frac{1}{8}$ " to 2" Standard Pipe (NPT)
 $\frac{1}{4}$ " to 2" Bolts or Studs UNC or UNF

Pipe Adapters	Stud Adapters
$\frac{1}{8}$ ", $\frac{1}{4}$ ", $\frac{3}{8}$ ", $\frac{1}{2}$ ", $\frac{3}{4}$ ", 1", $1\frac{1}{4}$ ", $1\frac{1}{2}$ "	$\frac{1}{4}$ " to 2" UNC $\frac{1}{4}$ " to $1\frac{1}{2}$ " UNF

Short or Close Nipple Threading Procedure

1. Grip pipe in machine chuck. Thread and ream one end and cut nipple to desired length.
2. Turn directional switch to OFF position and remove pipe.
3. Place nipple chuck body (Figure 23) in Power Drive chuck, gripping jaw grooves. Tighten chuck with snap spin of handwheel.
4. Position insert (Figure 23) with small end toward chuck body for $\frac{1}{8}$ " to $\frac{3}{4}$ " pipe; large end toward chuck body for 1" pipe; no insert required for $1\frac{1}{4}$ " pipe and up.

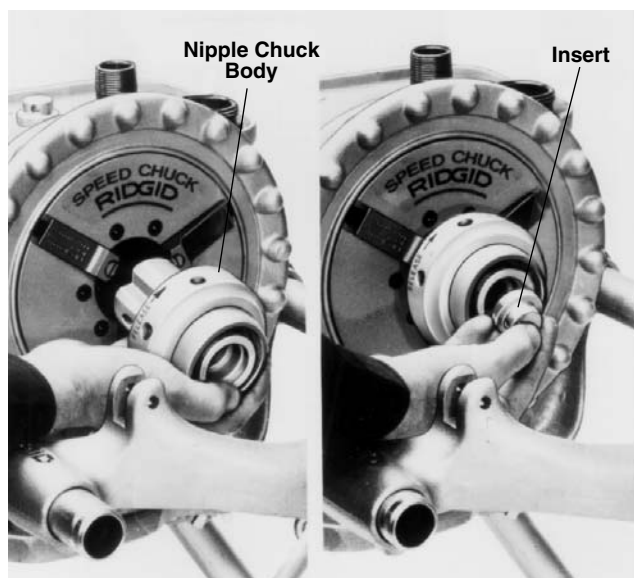

Figure 23 – Installing Nipple Chuck Body and Insert

5. Select proper size nipple chuck adapter and screw into nipple chuck (Figure 24) by hand. Tighten with wrench provided with nipple chuck.

▲ WARNING To prevent injury, remove wrench before turning on machine.

- Screw nipple (Figure 24) threaded on one end into adapter by hand. Turn directional switch to ON and press down on foot switch. Ream and thread other end.

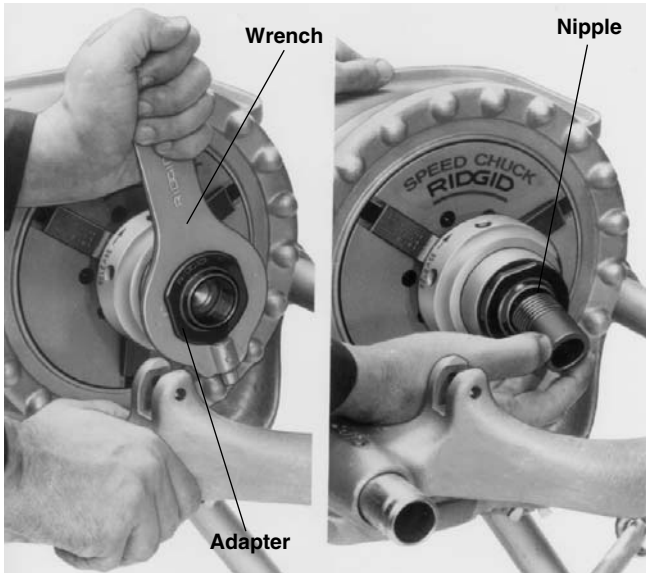

Figure 24 – Installing Nipple Chuck Adapter and Nipple

- Insert pin on end of wrench (Figure 25) into one of holes in nipple chuck release collar and turn. Remove threaded nipple by hand.

▲ WARNING To prevent injury, remove wrench before turning on machine.

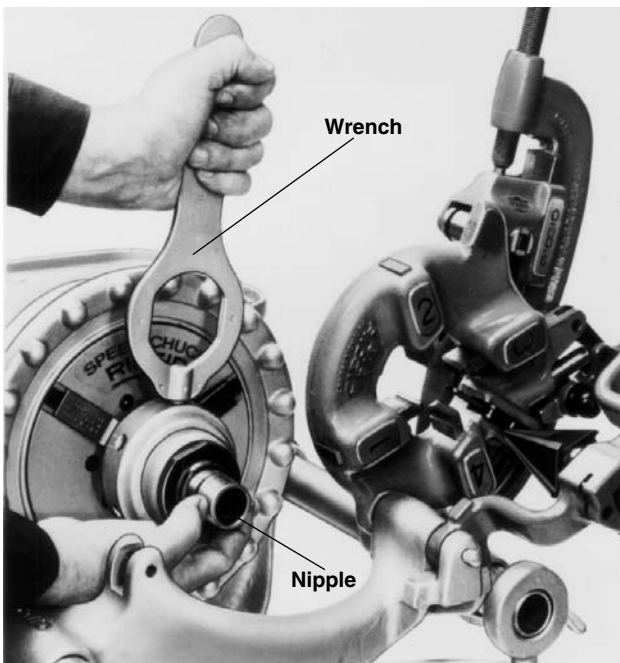

Figure 25 – Releasing Nipple from Nipple Chuck

Accessories

▲ WARNING

Only the following RIDGID products have been designed to function with the 300 Power Drive. Other accessories designed for use with other tools may become hazardous when used on this Power Drive. To prevent serious injury, use only the accessories listed below.

Accessories for Power Drive

Model No.	Description
1206	Stand for 300 Power Drive
32	Transporter (for Power Drives and Tri-Stand Vises)
819	Nipple Chuck Complete, 1/2" – 2" (12mm – 50 mm)
1452	Clip-On Tool Tray
–	Jaw Inserts for Coated Pipe
E-863	LH/RH Reamer Cone
–	Gearhead Motor Grease

Hand Tools Recommended for Use with Power Drive

Threaders:

- 12-R Pipe Threader
- OO-R Pipe Threader
- 11-R Pipe Threader
- OO-RB Bolt Threader

Cutters:

- No. 1-A and 2-A Cutter
- No. 202 Cutter

Reamers:

- No. 2 and 3 Ratchet Reamers

Contact a RIDGID distributor or consult the Ridge catalog for specifications and catalog numbers.

311A Carriage and Tools as Accessories

Model No.	Description
311	Carriage with No. 312 Lever
341	Reamer for No. 311 Carriage
360	Cutter for No. 311 Carriage
811A	Universal Quick Opening Die Head Only, Right Hand Only
815A	Self-Opening Die Head Only, Right Hand Only

Geared Threaders:

- No. 141 2-1/2" – 4" Pipe (NPT or BSPT)
- No. 161 4 – 6" Pipe (NPT or BSPT)

Accessories for Threading by Close-Coupled Method

Model No.	Description	Geared Threaders	
		141	161
	Pipe Supports		
758	Loop	X	
844	Drive Bar	X	X
346	Support Arm (2)		X
NOTE!	If gear case does not have loop hole, use No. 3675 Adapter Bracket instead of No. 758 Loop.		

Accessories for Threading with Drive Shaft

Catalog No.	Model No.	Description
61122	840-A	Universal Drive Shaft
72037	460	Tristand
42510	92	Adjustable Pipe Support

NOTE! See Ridge Tool catalog for listing of pipe support, thread cutting oil, die heads and dies.

Maintenance Instructions

▲ WARNING

Make sure machine is unplugged from power source before performing maintenance or making any adjustment.

Jaw Inserts

1. Clean teeth of jaw inserts daily with wire brush.
2. Replace jaw inserts when teeth become worn and fail to hold pipe or rod.

NOTE! Replace entire set of jaw inserts to insure proper gripping of the pipe or rod.

Jaw Insert Replacement

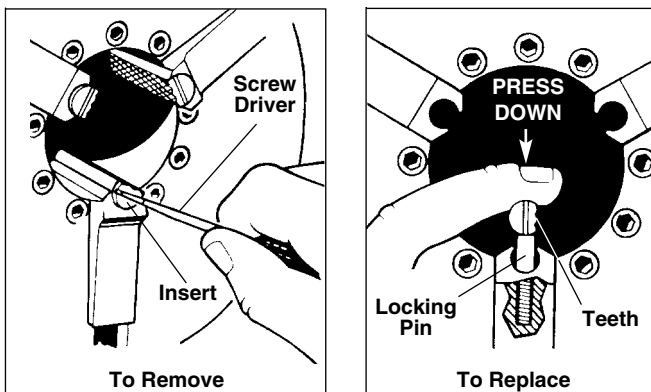

Figure 26 – Replacing Jaw Inserts

1. Place screwdriver in insert slot and turn 90 degrees in either direction.

2. Place insert sideways on locking pin and press down as far as possible.
3. Hold insert down firmly with screwdriver, turn until teeth face up.

Lubrication

Proper lubrication is essential to trouble-free operation and long life of Power Drive.

Grease main shaft bearings every 2 to 6 months depending upon amount of Power Drive use. Grease fittings are provided on side base, one at each end of shaft. Use a good grade of cup grease.

Motor Brush Replacement

1. Check motor brushes every six (6) months and replace when worn to less than 1/2 inch.
2. If communicator is worn, the outer dimension of the communicator should be turned and the mica should be undercut before replacing brushes. This should only be done by qualified repair personnel.

Motor Replacement

1. Unplug motor receptacle from switch box.
2. Remove two (2) screws (E-891) holding motor.
3. Loosen back screw (E-4548) in body at neck of motor and lift motor out.

Machine Storage

▲ WARNING Motor-driven equipment must be kept indoors or well covered in rainy weather. Store the machine in a locked area that is out of reach of children and people unfamiliar with power drives. This machine can cause serious injury in the hands of untrained users.

Service and Repair

▲ WARNING



Service and repair work on this Power Drive must be performed by qualified repair personnel. Power Drive should be taken to a RIDGID Independent Authorized Service Center or returned to the factory. All repairs made by Ridge service facilities are warranted against defects in material and workmanship.

When servicing the Power Drive, only identical replacement parts should be used. Failure to follow these instructions may create a risk of electrical shock or other serious injury.

If you have any questions regarding the service or repair of this machine, call or write to:

Ridge Tool Company
 Technical Service Department
 400 Clark Street
 Elyria, Ohio 44035-6001
 Tel: (800) 519-3456



Wiring Diagram (115/230V)

1. Brush and Armature Leads may be solid colors or white with a colored stripe.
2. Wire Colors in parenthesis represent European color code. European cord is the same except for plug.

