

TECHNICAL CATALOGUE

---

# CONVERTIBLE VALVES FOR RADIATORS





ITAP SpA, founded in Lumezzane (Brescia) in 1972, is currently one of the leading production companies in Italy of valves, fittings and distribution manifolds for plumbing and heating systems. Thanks to fully automated production processes, with 72 tooling machines and 51 assembly lines, we are able to produce 200,000 pieces per day. Our innate pursuit for innovation and observance of technical regulations is supported by the company certification ISO 9001: 2008. The company has always considered its focus on quality as the main tool to obtain significant business results: today ITAP SpA is proud to offer products bearing the approval of numerous international certifying bodies.

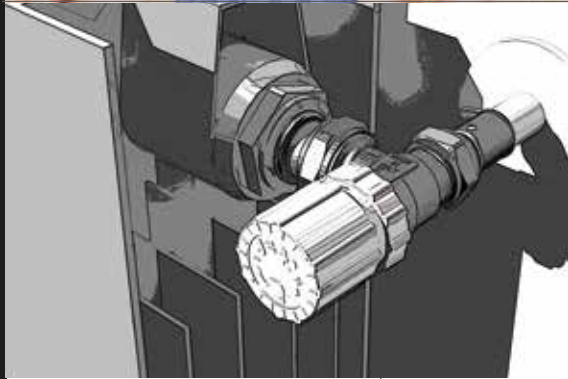

CONVERTIBLE VALVES



# Thermostatic

valves are used as **fluid heat-carrying shut-off elements** feeding into radiators. They are composed of valves furnished with a special internal bonnet that is able to permit or stop the flow of water when it is combined with a thermostatic control head. This enables **setting the maximum reachable temperature in a room**: once the said temperature has been reached, the thermostatic control head, by pressing the bonnet, closes the valve completely, thus isolating the radiator from the rest of the system. If the temperature next to the thermostatic control head does not represent that of the room (for example, because there is a radiator cover), it is advised to install the thermostatic control head with a remote sensor Art. 891SD.

ITA P SpA thermostatic valves are **classified as low inertia** since, when there is a change in temperature of the room, the response of the thermostatic control head occurs within and not beyond an interval of 40 minutes.

Should it be necessary to prevent the set temperature on the thermostatic control head from being changed, it is possible to block regulation directly from the control head.

To facilitate installation, **the valve shanks and lockshields are pre-supplied with an O-ring seal.**





AVAILABLE SIZES: 3/8" - 1/2", articles 894C, 994C, 296S and 396S are also available in size 3/4".  
 To be used with iron piping or, together with an Itap-Fit® connector (art. 618), with copper, crosslinked polyethylene (PEX) or polybutylene. In the case of use with PEX or polybutylene it is also requested the use of the liner (art. 655).

Suitable for thermostatic control heads art. 891 and art. 891SD



AVAILABLE SIZES: 3/8" - 1/2"  
 To be used with multilayer, PEX or polybutylene piping, together with 595M or 510 Multi-Fit® connectors.  
 Suitable also for copper piping, together with a compression fitting (art. 595).

Suitable for thermostatic control heads art. 891 and art. 891SD

The male thread "G" is equipped with a conical seat and inner diameter mm.16.



## SPECIFICATION ENTRIES



Body: nickel-plated brass CW617N.  
Stem: brass CW614N.  
O-ring: EPDM or NBR.  
Maximum working temperature: 110°C.  
Maximum working pressure: 10 bar.  
Means of: water, glycol solutions.  
Maximum glycolic percentage: 30%.  
Maximum differential pressure,  
with thermostatic control head: 1,5 bar.  
Threads: ISO 228 (equivalent to DIN EN ISO 228 and  
BS EN ISO 228).

## VALVE TECHNICAL SPECIFICATIONS

The thermostatic valve is composed of a brass body and bonnet with a pin and counterspring in stainless steel. The thermostatic control head is a temperature proportion regulator composed of an internal sensor with an oil-filled element. Once the temperature has been set on the control head, it directly activates the iron pin, thus determining the position (closing or opening). If room temperature is below the set value, the liquid contracts and increases the opening of the valve. If room temperature is above the set value, the liquid expands and decreases the opening of the valve until it closes completely (once it has reached the desired temperature).

## LOCKSHIELDS TECHNICAL SPECIFICATIONS

Thanks to the internal bonnet, the lockshield's function is to give perfect balance to the system. With this component, it is possible to supply all radiators, even the most disadvantaged ones, in a perfect way. In order to carry out perfect balance of the various circuits, it is recommended to use the load flow / loss diagram found in this technical catalogue.

## CONDITIONS OF USE OF THERMOSTATIC CONTROL HEADS

Scale value: from \* to 5.  
Adjustable temperature range: 6.5°C, 28°C  
Antifreeze position: 6.5°C  
Device to restrict or lock temperature  
setting included.  
Hysteresis: 0.5K  
Water temperature effect (W): 0.75K  
Response time (Z): 30 minutes  
Maximum differential pressure: 1.5 bar

# 894V

STRAIGHT CONVERTIBLE  
VALVE WITH HANDLE,  
FEMALE THREAD



SIZE	PRESSURE	CODE	PACKING
3/8" (DN 10)	10bar/145psi	8940038V	4/120
1/2" (DN 15)	10bar/145psi	8940012V	4/84

## MATERIALS

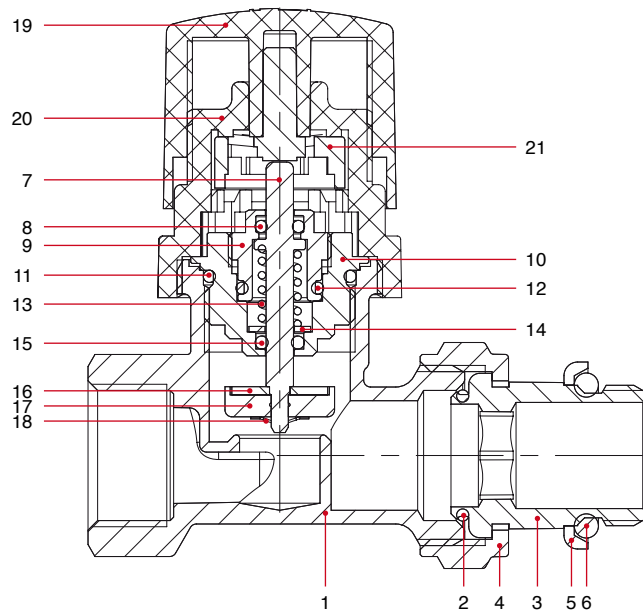

POS.	DESCRIPTION	N.	MATERIAL
1	Body	1	Nickel-plated brass CW617N
2	O-ring	1	NBR
3	Union	1	Nickel-plated brass CW617N
4	Nut	1	Nickel-plated brass CW617N
5	Ring	1	Zinc-plated steel Fe
6	O-ring	1	NBR
7	Stem	1	Brass CW614N
8	O-ring	1	EPDM
9	Ring nut	1	Brass CW614N
10	Body	1	Brass CW614N
11	O-ring	1	EPDM
12	O-ring	1	EPDM
13	Spring	1	Stainless steel AISI 302
14	Washer	1	Stainless steel AISI 304
15	O-ring	1	EPDM
16	Washer	1	Stainless steel AISI 304
17	Washer	1	EPDM
18	Seeger	1	Stainless steel AISI 304
19	Cap	1	ABS
20	Body	1	ABS
21	Hook	1	Polycarbonate





## OVERALL DIMENSIONS

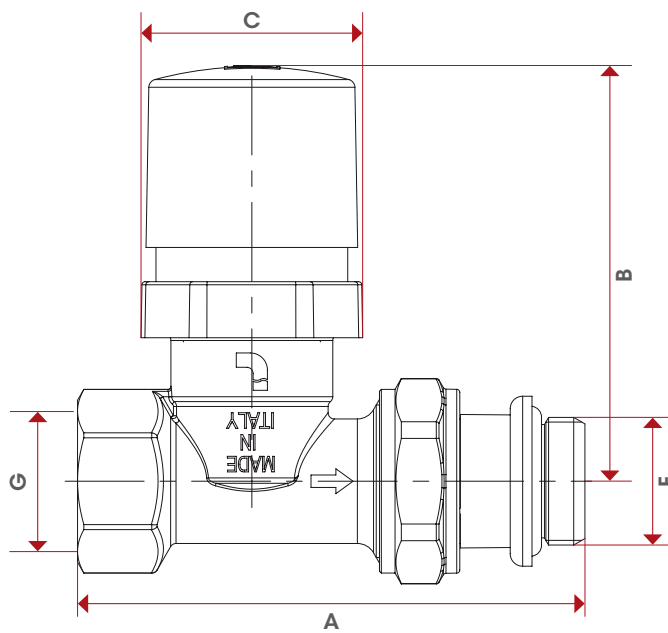

	3/8"	1/2"
DN	10	15
A	75	81,5
B	66,8	66,8
C	35,6	35,6
F	3/8"	1/2"
G	3/8"	1/2"
Kg/cm <sup>2</sup> bar	10	10
LBS - psi	145	145

## CERTIFICATIONS



# 894C

STRAIGHT  
CONVERTIBLE VALVE  
WITH CAP,  
FEMALE THREAD



SIZE	PRESSURE	CODE	PACKING
3/8" (DN 10)	10bar/145psi	8940038C	4/120
1/2" (DN 15)	10bar/145psi	8940012C	4/96
3/4" (DN 20)	10bar/145psi	8940034C	10/80

## MATERIALS

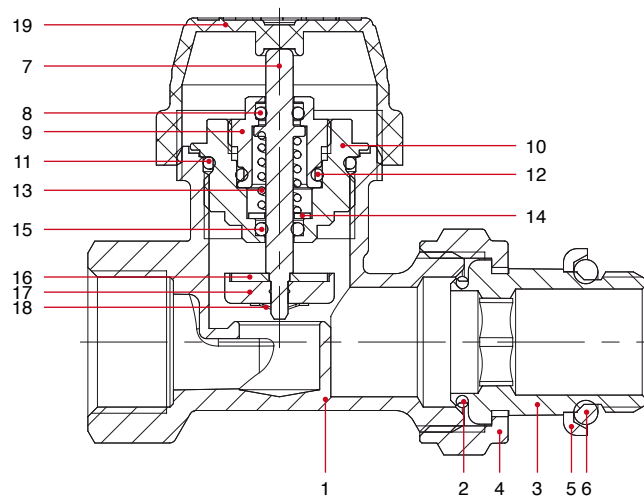

POS.	DESCRIPTION	N.	MATERIAL
1	Body	1	Nickel-plated brass CW617N
2	O-ring	1	NBR
3	Union	1	Nickel-plated brass CW617N
4	Nut	1	Nickel-plated brass CW617N
5	Ring	1	Zinc-plated steel Fe
6	O-ring	1	NBR
7	Stem	1	Brass CW614N
8	O-ring	1	EPDM
9	Ring nut	1	Brass CW614N
10	Body	1	Brass CW614N
11	O-ring	1	EPDM
12	O-ring	1	EPDM
13	Spring	1	Stainless steel AISI 302
14	Washer	1	Stainless steel AISI 304
15	O-ring	1	EPDM
16	Washer	1	Stainless steel AISI 304
17	Washer	1	EPDM
18	Seeger	1	Stainless steel AISI 304
19	Cap	1	ABS



## OVERALL DIMENSIONS

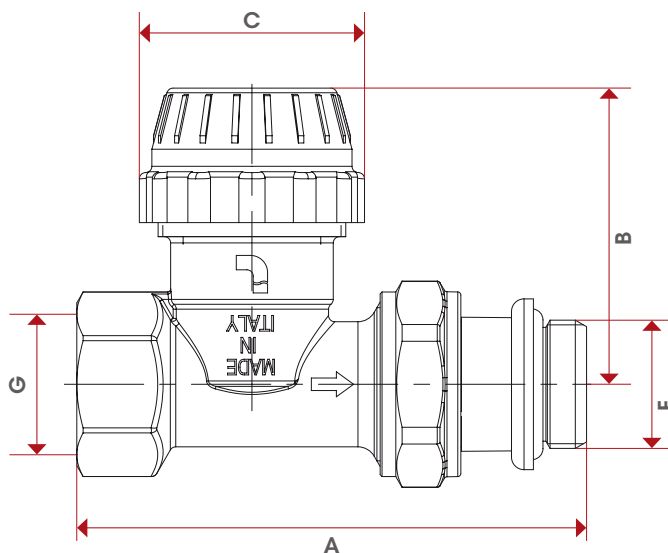

	3/8"	1/2"	3/4"
DN	10	15	20
A	75	81,5	97,5
B	47,3	47,3	43,7
C	36	36	36
F	3/8"	1/2"	3/4"
G	3/8"	1/2"	3/4"
Kg/cm <sup>2</sup> bar	10	10	10
LBS - psi	145	145	145

## CERTIFICATIONS



# 895V

STRAIGHT CONVERTIBLE VALVE WITH HANDLE, MALE THREAD



SIZE	PRESSURE	CODE	PACKING
3/8" (DN 10)	10bar/145psi	8950038V	4/120
1/2" (DN 15)	10bar/145psi	8950012V	4/84

## MATERIALS

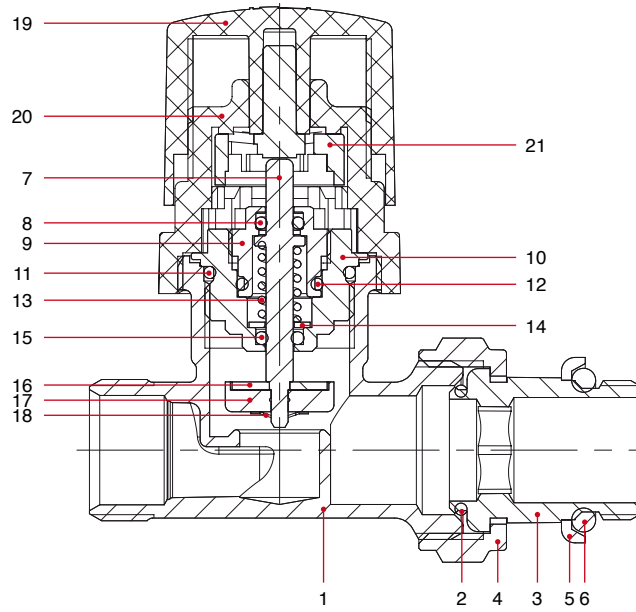

POS.	DESCRIPTION	N.	MATERIAL
1	Body	1	Nickel-plated brass CW617N
2	O-ring	1	NBR
3	Union	1	Nickel-plated brass CW617N
4	Nut	1	Nickel-plated brass CW617N
5	Ring	1	Zinc-plated steel Fe
6	O-ring	1	NBR
7	Stem	1	Brass CW614N
8	O-ring	1	EPDM
9	Ring nut	1	Brass CW614N
10	Body	1	Brass CW614N
11	O-ring	1	EPDM
12	O-ring	1	EPDM
13	Spring	1	Stainless steel AISI 302
14	Washer	1	Stainless steel AISI 304
15	O-ring	1	EPDM
16	Washer	1	Stainless steel AISI 304
17	Washer	1	EPDM
18	Seeger	1	Stainless steel AISI 304
19	Cap	1	ABS
20	Body	1	ABS
21	Hook	1	Polycarbonate



## OVERALL DIMENSIONS

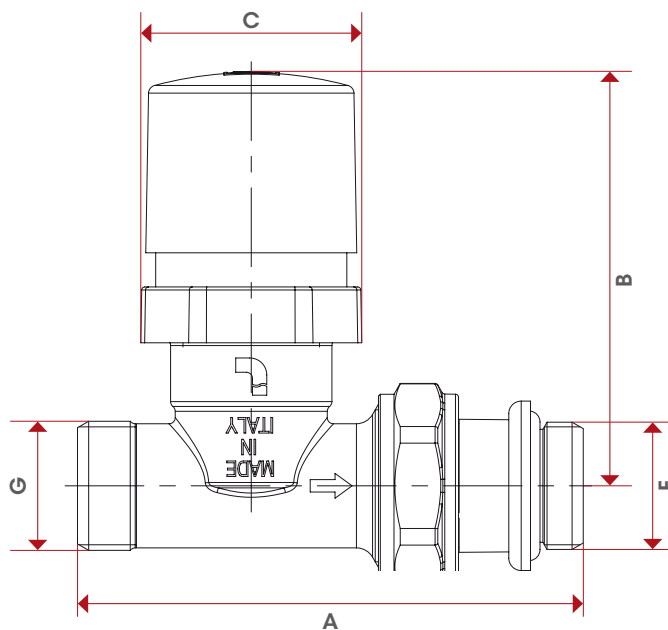

	3/8"	1/2"
DN	10	15
A	75	81,5
B	66,8	66,8
C	35,6	36
F	3/8"	1/2"
G	1/2"	1/2"
Kg/cm <sup>2</sup> bar	10	10
LBS - psi	145	145

## CERTIFICATIONS



# 895C

STRAIGHT  
CONVERTIBLE VALVE  
WITH CAP,  
MALE THREAD



SIZE	PRESSURE	CODE	PACKING
3/8" (DN 10)	10bar/145psi	8950038C	4/120
1/2" (DN 15)	10bar/145psi	8950012C	4/96

## MATERIALS

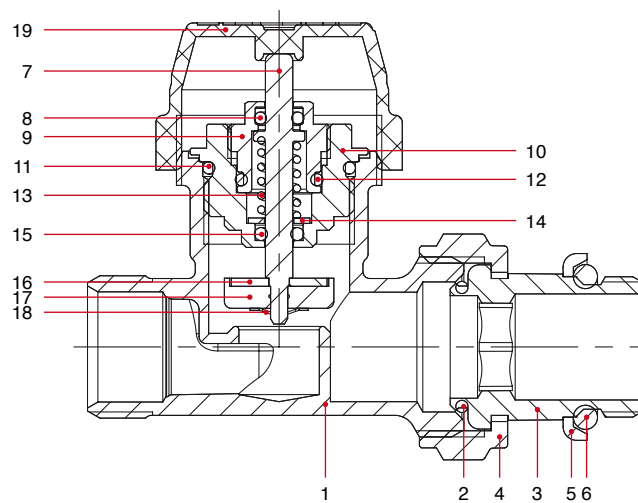

POS.	DESCRIPTION	N.	MATERIAL
1	Body	1	Nickel-plated brass CW617N
2	O-ring	1	NBR
3	Union	1	Nickel-plated brass CW617N
4	Nut	1	Nickel-plated brass CW617N
5	Ring	1	Zinc-plated steel Fe
6	O-ring	1	NBR
7	Stem	1	Brass CW614N
8	O-ring	1	EPDM
9	Ring nut	1	Brass CW614N
10	Body	1	Brass CW614N
11	O-ring	1	EPDM
12	O-ring	1	EPDM
13	Spring	1	Stainless steel AISI 302
14	Washer	1	Stainless steel AISI 304
15	O-ring	1	EPDM
16	Washer	1	Stainless steel AISI 304
17	Washer	1	EPDM
18	Seeger	1	Stainless steel AISI 304
19	Cap	1	ABS





## OVERALL DIMENSIONS

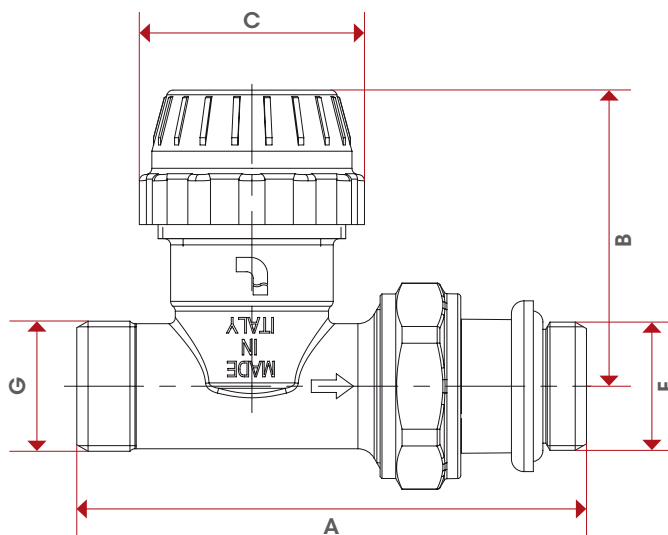

	3/8"	1/2"
DN	10	15
A	75	81,5
B	47,3	47,3
C	36	36
F	3/8"	1/2"
G	1/2"	1/2"
Kg/cm <sup>2</sup> bar	10	10
LBS - psi	145	145

## CERTIFICATIONS



# 296S

STRAIGHT LOCKSHIELD,  
FEMALE THREAD



SIZE	PRESSURE	CODE	PACKING
3/8" (DN 10)	10bar/145psi	2960038S	12/132
1/2" (DN 15)	10bar/145psi	2960012S	12/132
3/4" (DN 20)	10bar/145psi	2960034S	8/104



## MATERIALS

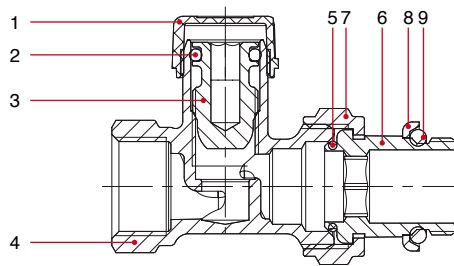

POS.	DESCRIPTION	N.	MATERIAL
1	Cap	1	ABS
2	O-ring	1	EPDM
3	Bonnet	1	Brass CW614N
4	Body	1	Nickel-plated brass CW617N
5	O-ring	1	NBR
6	Union	1	Nickel-plated brass CW617N
7	Nut	1	Nickel-plated brass CW617N
8	Ring	1	Zinc-plated steel Fe
9	O-ring	1	NBR

## OVERALL DIMENSIONS

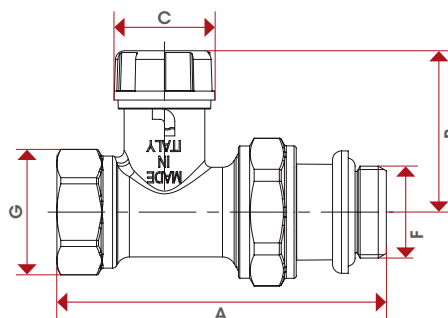

	3/8"	1/2"	3/4"
DN	10	15	20
A	72	73,5	77,5
B	36	36	39
C	22,5	22,5	25
F	3/8"	1/2"	3/4"
G	3/8"	1/2"	3/4"
Kg/cm <sup>2</sup> bar	10	10	10
LBS - psi	145	145	145



# 297S

STRAIGHT LOCKSHIELD,  
MALE THREAD



SIZE	PRESSURE	CODE	PACKING
3/8" (DN 10)	10bar/145psi	2970038S	12/192
1/2" (DN 15)	10bar/145psi	2970012S	12/156



## MATERIALS

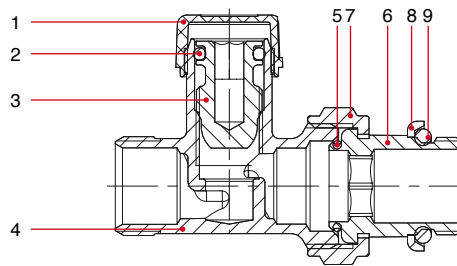

POS.	DESCRIPTION	N.	MATERIAL
1	Cap	1	ABS
2	O-ring	1	EPDM
3	Bonnet	1	Brass CW614N
4	Body	1	Nickel-plated brass CW617N
5	O-ring	1	NBR
6	Union	1	Nickel-plated brass CW617N
7	Nut	1	Nickel-plated brass CW617N
8	Ring	1	Zinc-plated steel Fe
9	O-ring	1	NBR

## OVERALL DIMENSIONS

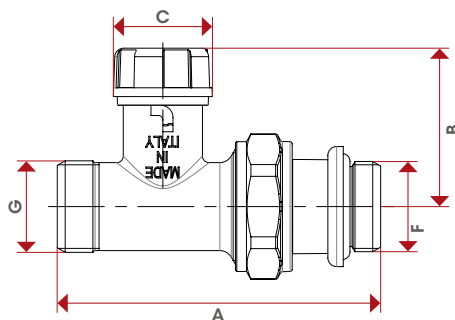

	3/8"	1/2"
DN	10	15
A	72	73,5
B	36	36
C	22,5	22,5
F	3/8"	1/2"
G	3/8"	1/2"
Kg/cm <sup>2</sup> bar	10	10
LBS - psi	145	145

894 - 895  
3/8"

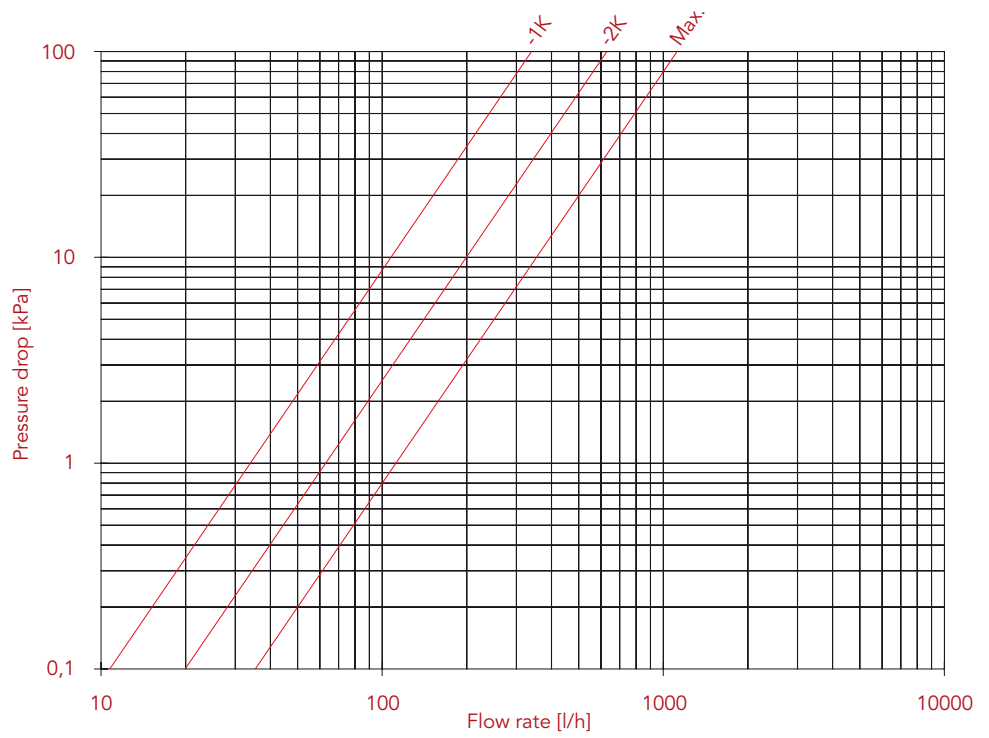
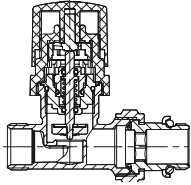
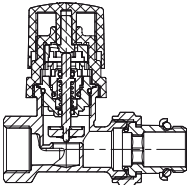

SIZE	3/8"		
-	-1K	-2K	Max
Kv	0,34	0,63	1,12

With water

894 - 895  
1/2"

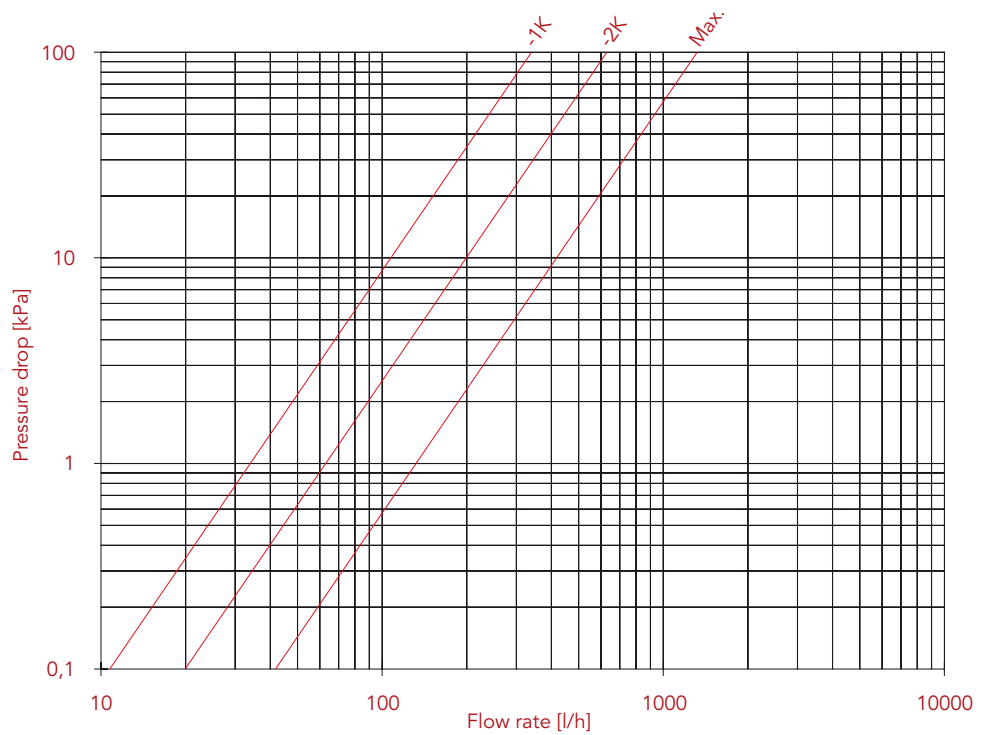
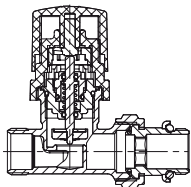
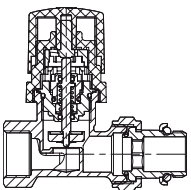

SIZE	1/2"		
-	-1K	-2K	Max
Kv	0,34	0,63	1,32

With water



894  
3/4"

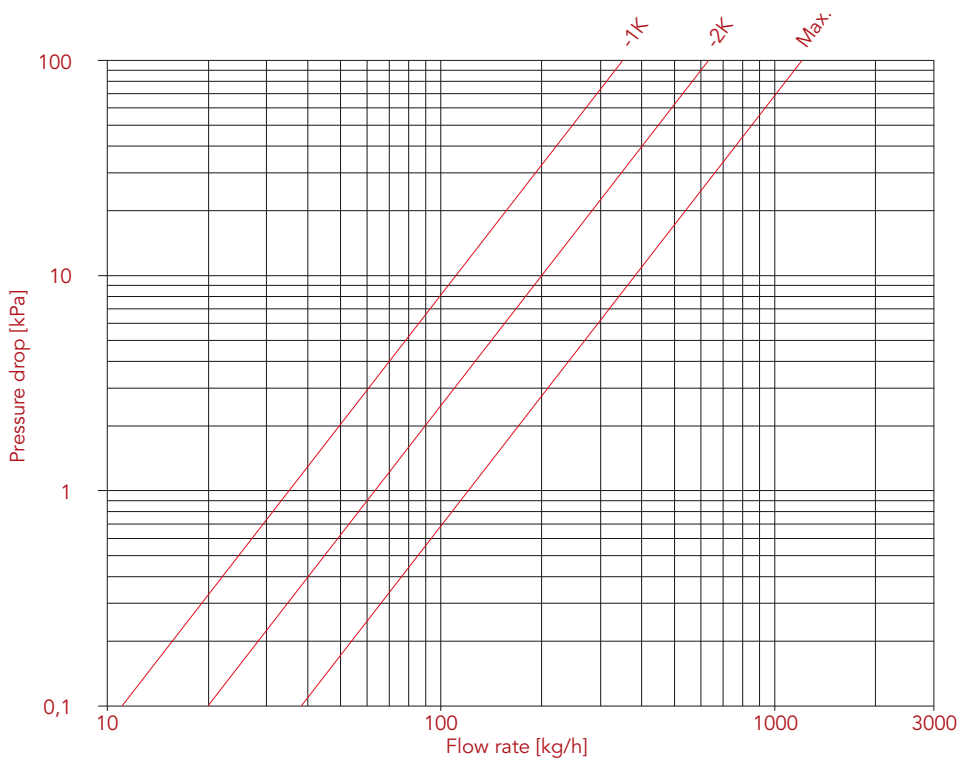
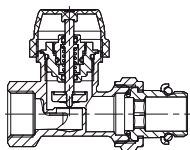

SIZE	3/4"		
-	-1K	-2K	Max
Kv	0,35	0,63	1,20

With water

296S - 297S  
3/8"

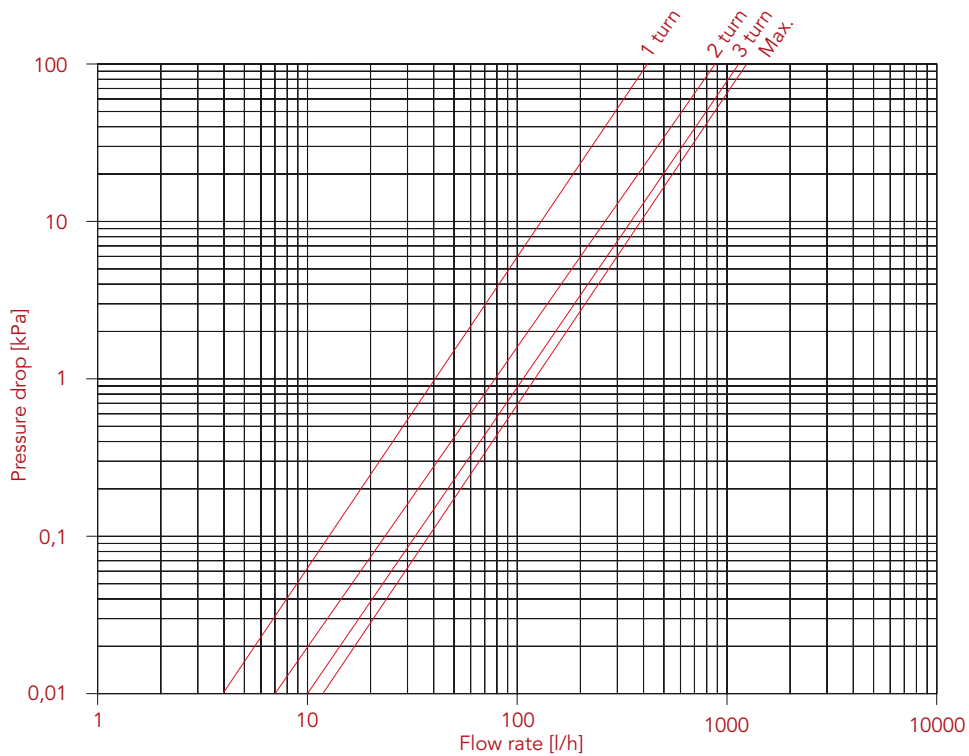
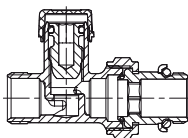
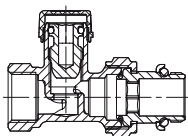

SIZE	3/8"			
Turn	1	2	3	Open
Kv	0,4	0,9	1,1	1,26

With water

296S - 297S  
1/2"

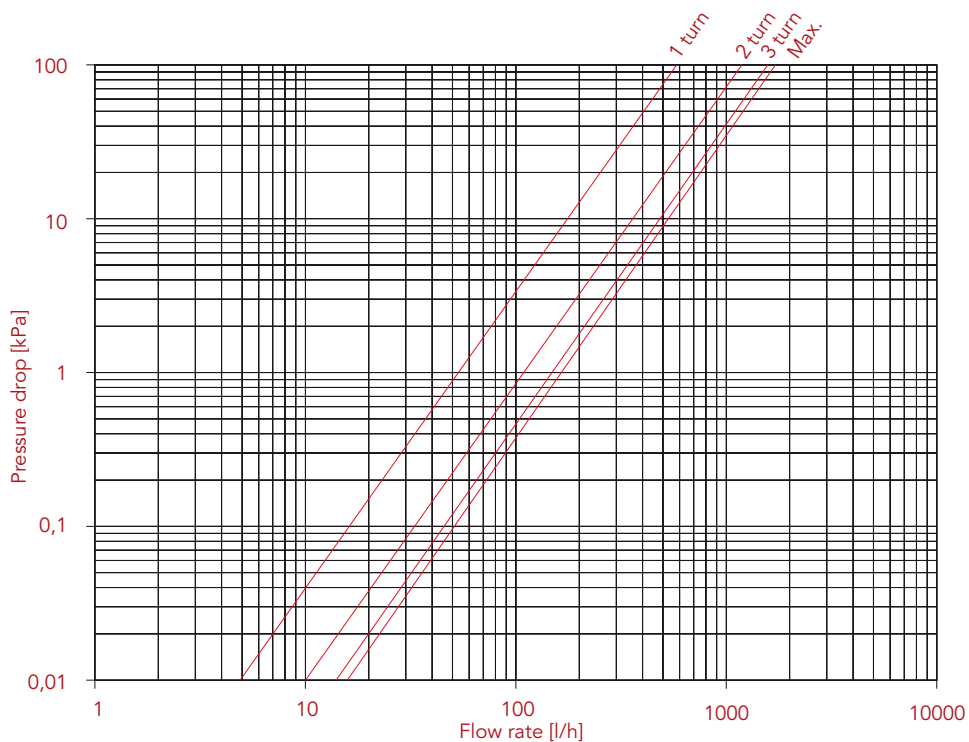
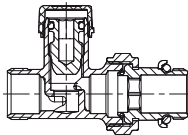
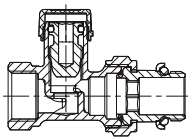

SIZE	1/2"			
Turn	1	2	3	Open
Kv	0,6	1,2	1,6	1,72

With water





296S  
3/4"

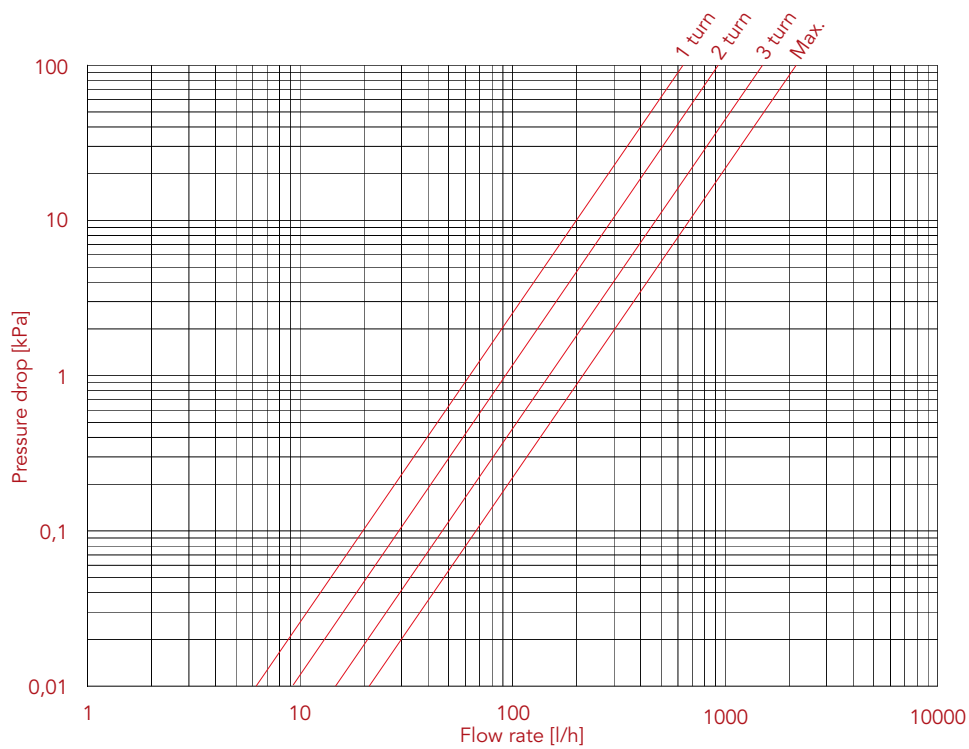
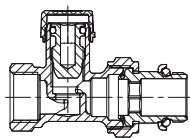

SIZE	3/4"			
Turn	1	2	3	Open
Kv	0,6	0,9	1,5	2,15

With water

# 994V

ANGLE CONVERTIBLE  
VALVE WITH HANDLE,  
FEMALE THREAD



SIZE	PRESSURE	CODE	PACKING
3/8" (DN 10)	10bar/145psi	9940038V	4/120
1/2" (DN 15)	10bar/145psi	9940012V	4/84

## MATERIALS

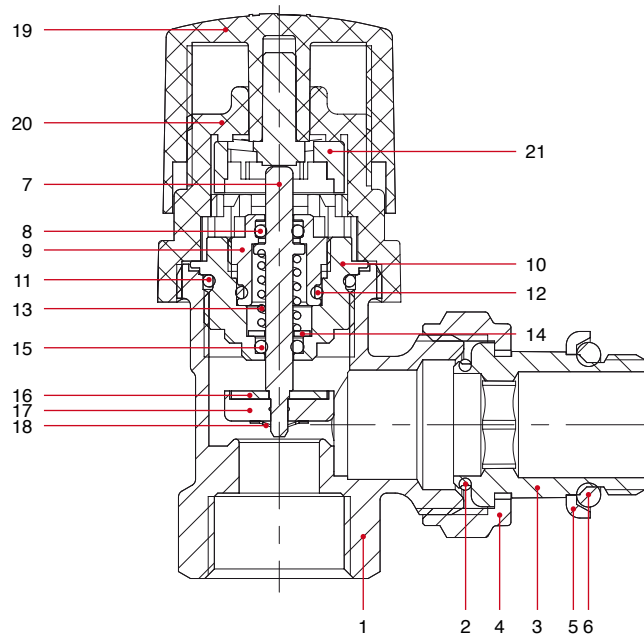

POS.	DESCRIPTION	N.	MATERIAL
1	Body	1	Nickel-plated brass CW617N
2	O-ring	1	NBR
3	Union	1	Nickel-plated brass CW617N
4	Nut	1	Nickel-plated brass CW617N
5	Ring	1	Zinc-plated steel Fe
6	O-ring	1	NBR
7	Stem	1	Brass CW614N
8	O-ring	1	EPDM
9	Ring nut	1	Brass CW614N
10	Body	1	Brass CW614N
11	O-ring	1	EPDM
12	O-ring	1	EPDM
13	Spring	1	Stainless steel AISI 302
14	Washer	1	Stainless steel AISI 304
15	O-ring	1	EPDM
16	Washer	1	Stainless steel AISI 304
17	Washer	1	EPDM
18	Seeger	1	Stainless steel AISI 304
19	Cap	1	ABS
20	Body	1	ABS
21	Hook	1	Polycarbonate



OVERALL  
DIMENSIONS

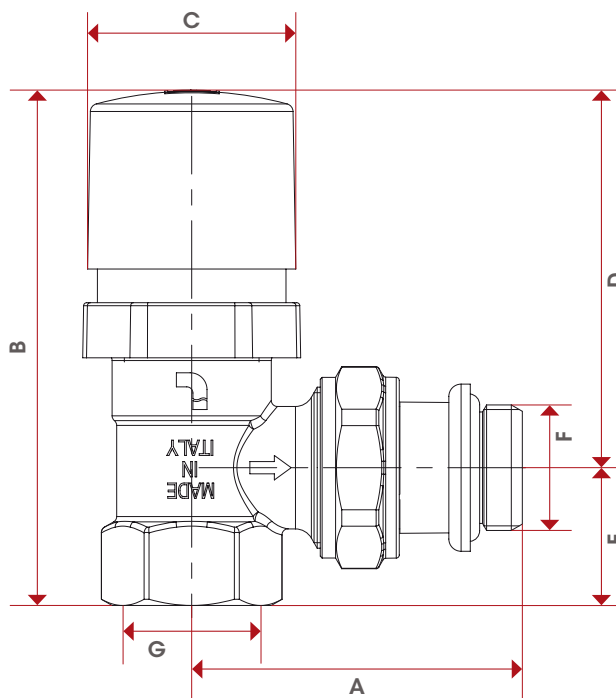

	3/8"	1/2"
DN	10	15
A	49,5	54
B	82,2	84,2
C	35,6	35,6
D	61,7	61,7
E	20,5	22,5
F	3/8"	1/2"
G	3/8"	1/2"
Kg/cm <sup>2</sup> bar	10	10
LBS - psi	145	145

CERTIFICATIONS



# 994C

ANGLE  
CONVERTIBLE VALVE  
WITH CAP,  
FEMALE THREAD



SIZE	PRESSURE	CODE	PACKING
3/8" (DN 10)	10bar/145psi	9940038C	4/120
1/2" (DN 15)	10bar/145psi	9940012C	4/96
3/4" (DN 20)	10bar/145psi	9940034C	10/80

## MATERIALS

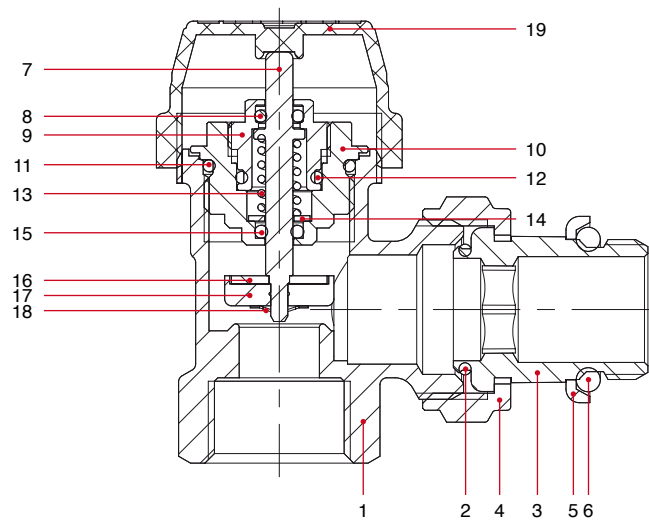

POS.	DESCRIPTION	N.	MATERIAL
1	Body	1	Nickel-plated brass CW617N
2	O-ring	1	NBR
3	Union	1	Nickel-plated brass CW617N
4	Nut	1	Nickel-plated brass CW617N
5	Ring	1	Zinc-plated steel Fe
6	O-ring	1	NBR
7	Stem	1	Brass CW614N
8	O-ring	1	EPDM
9	Ring nut	1	Brass CW614N
10	Body	1	Brass CW614N
11	O-ring	1	EPDM
12	O-ring	1	EPDM
13	Spring	1	Stainless steel AISI 302
14	Washer	1	Stainless steel AISI 304
15	O-ring	1	EPDM
16	Washer	1	Stainless steel AISI 304
17	Washer	1	EPDM
18	Seeger	1	Stainless steel AISI 304
19	Cap	1	ABS



## OVERALL DIMENSIONS

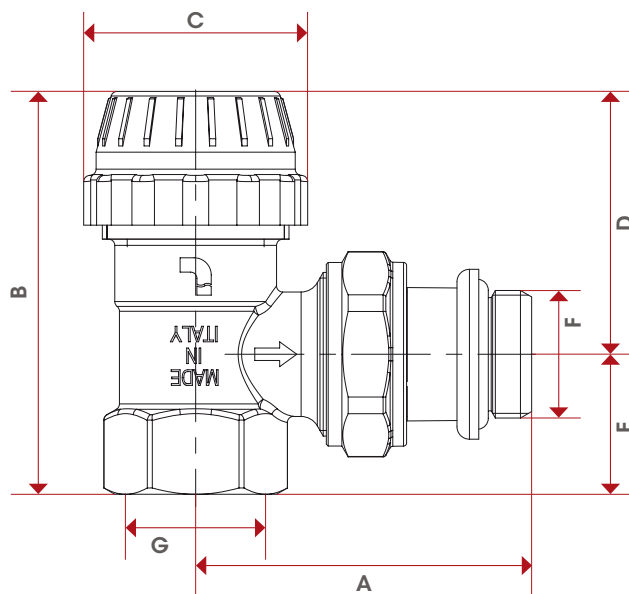

	3/8"	1/2"	3/4"
DN	10	15	20
A	49,5	54	62,5
B	62,3	64,3	59,5
C	36	36	36
D	42,2	42,2	33,5
E	20,5	22,5	26
F	3/8"	1/2"	3/4"
G	3/8"	1/2"	3/4"
Kg/cm <sup>2</sup> bar	10	10	10
LBS - psi	145	145	145

## CERTIFICATIONS



# 995V

ANGLE CONVERTIBLE  
VALVE WITH HANDLE,  
MALE THREAD



SIZE	PRESSURE	CODE	PACKING
3/8" (DN 10)	10bar/145psi	9950038V	4/120
1/2" (DN 15)	10bar/145psi	9950012V	4/84

## MATERIALS

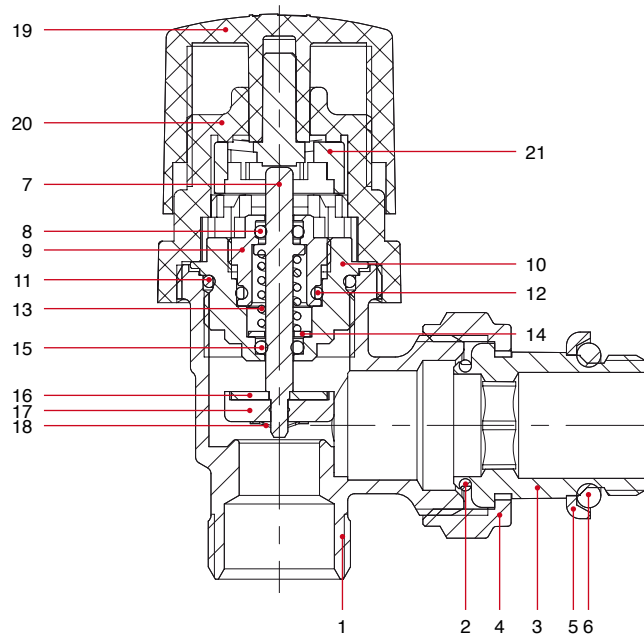

POS.	DESCRIPTION	N.	MATERIAL
1	Body	1	Nickel-plated brass CW617N
2	O-ring	1	NBR
3	Union	1	Nickel-plated brass CW617N
4	Nut	1	Nickel-plated brass CW617N
5	Ring	1	Zinc-plated steel Fe
6	O-ring	1	NBR
7	Stem	1	Brass CW614N
8	O-ring	1	EPDM
9	Ring nut	1	Brass CW614N
10	Body	1	Brass CW614N
11	O-ring	1	EPDM
12	O-ring	1	EPDM
13	Spring	1	Stainless steel AISI 302
14	Washer	1	Stainless steel AISI 304
15	O-ring	1	EPDM
16	Washer	1	Stainless steel AISI 304
17	Washer	1	EPDM
18	Seeger	1	Stainless steel AISI 304
19	Cap	1	ABS
20	Body	1	ABS
21	Hook	1	Polycarbonate





## OVERALL DIMENSIONS

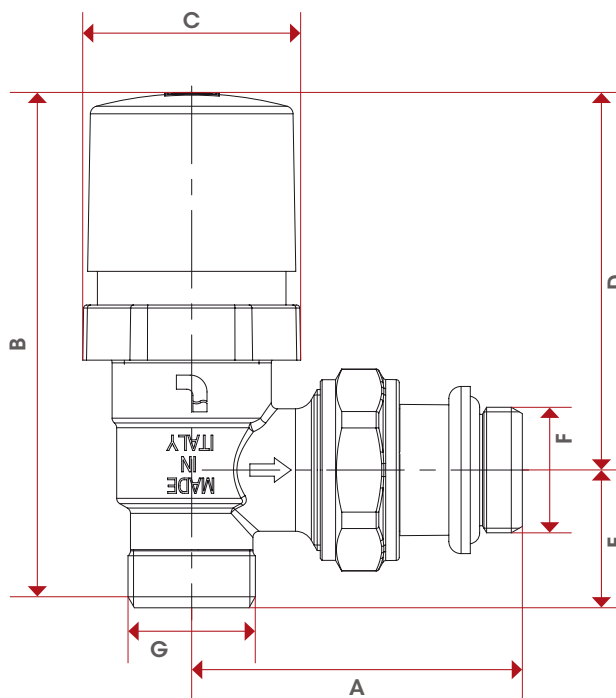

	3/8"	1/2"
DN	10	15
A	49,5	54
B	82,2	84,2
C	35,6	35,6
D	61,7	61,7
E	20,5	22,5
F	3/8"	1/2"
G	1/2"	1/2"
Kg/cm <sup>2</sup> bar	10	10
LBS - psi	145	145

## CERTIFICATIONS



# 995C

ANGLE  
CONVERTIBLE VALVE  
WITH CAP,  
MALE THREAD



SIZE	PRESSURE	CODE	PACKING
3/8" (DN 10)	10bar/145psi	9950038C	4/120
1/2" (DN 15)	10bar/145psi	9950012C	4/96

## MATERIALS

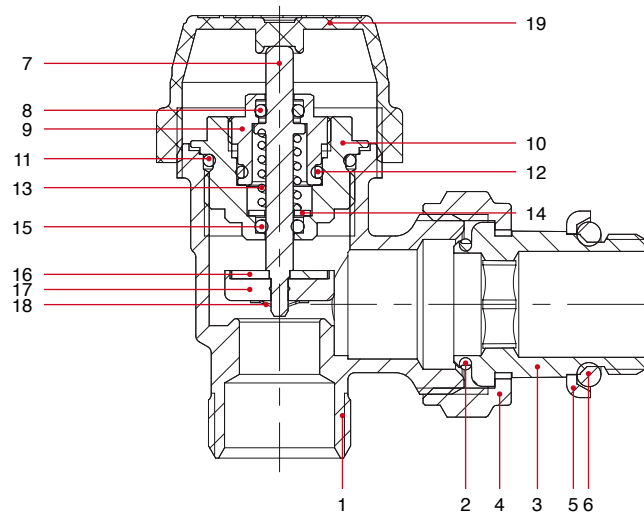

POS.	DESCRIPTION	N.	MATERIAL
1	Body	1	Nickel-plated brass CW617N
2	O-ring	1	NBR
3	Union	1	Nickel-plated brass CW617N
4	Nut	1	Nickel-plated brass CW617N
5	Ring	1	Zinc-plated steel Fe
6	O-ring	1	NBR
7	Stem	1	Brass CW614N
8	O-ring	1	EPDM
9	Ring nut	1	Brass CW614N
10	Body	1	Brass CW614N
11	O-ring	1	EPDM
12	O-ring	1	EPDM
13	Spring	1	Stainless steel AISI 302
14	Washer	1	Stainless steel AISI 304
15	O-ring	1	EPDM
16	Washer	1	Stainless steel AISI 304
17	Washer	1	EPDM
18	Seeger	1	Stainless steel AISI 304
19	Cap	1	ABS



## OVERALL DIMENSIONS

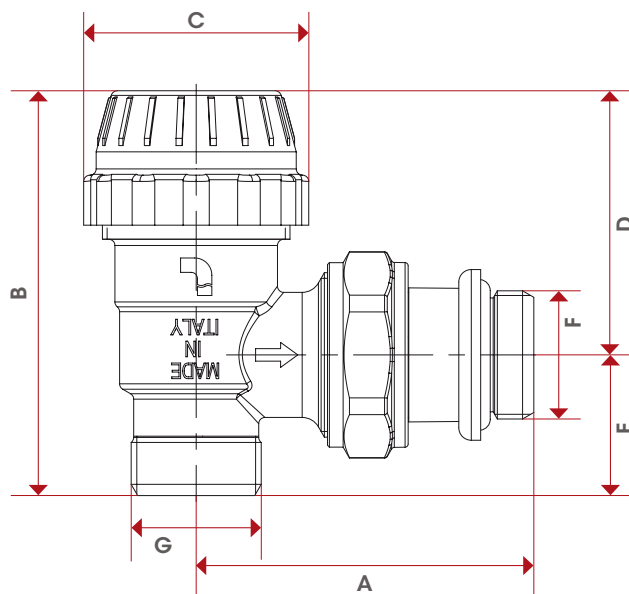

	3/8"	1/2"
DN	10	15
A	49,5	54
B	62,7	64,7
C	36	36
D	42,2	42,2
E	20,5	22,5
F	3/8"	1/2"
G	1/2"	1/2"
Kg/cm <sup>2</sup> bar	10	10
LBS - psi	145	145

## CERTIFICATIONS



# 396S

ANGLE LOCKSHIELD,  
FEMALE THREAD



SIZE	PRESSURE	CODE	PACKING
3/8" (DN 10)	10bar/145psi	3960038S	12/132
1/2" (DN 15)	10bar/145psi	3960012S	12/156
3/4" (DN 20)	10bar/145psi	3960034S	8/104



## MATERIALS

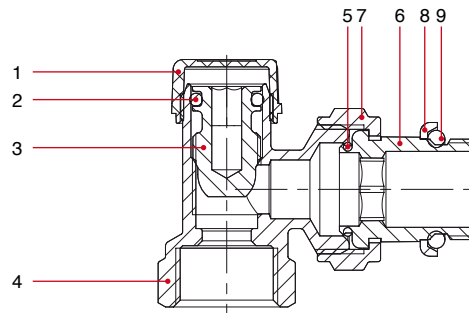

POS.	DESCRIPTION	N.	MATERIAL
1	Cap	1	ABS
2	O-ring	1	EPDM
3	Bonnet	1	Brass CW614N
4	Body	1	Nickel-plated brass CW617N
5	O-ring	1	NBR
6	Union	1	Nickel-plated brass CW617N
7	Nut	1	Nickel-plated brass CW617N
8	Ring	1	Zinc-plated steel Fe
9	O-ring	1	NBR

## OVERALL DIMENSIONS

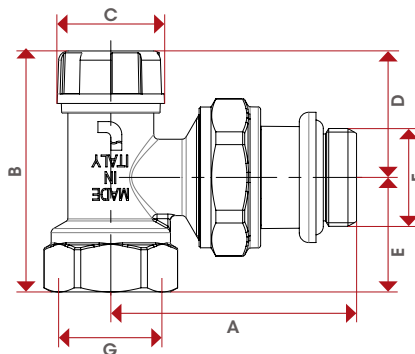

	3/8"	1/2"	3/4"
DN	10	15	20
A	50	51,5	58
B	48	50,5	53,7
C	22,5	22,5	25
D	26,5	26,5	30,3
E	21,5	24	23,4
F	3/8"	1/2"	3/4"
G	3/8"	1/2"	3/4"
Kg/cm <sup>2</sup> bar	10	10	10
LBS - psi	145	145	145



# 397S

ANGLE LOCKSHIELD,  
MALE THREAD



SIZE	PRESSURE	CODE	PACKING
3/8" (DN 10)	10bar/145psi	3970038S	12/132
1/2" (DN 15)	10bar/145psi	3970012S	12/192



## MATERIALS

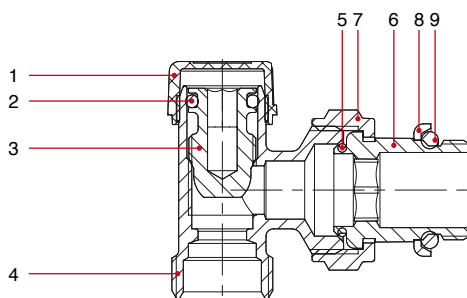

POS.	DESCRIPTION	N.	MATERIAL
1	Cap	1	ABS
2	O-ring	1	EPDM
3	Bonnet	1	Brass CW614N
4	Body	1	Nickel-plated brass CW617N
5	O-ring	1	NBR
6	Union	1	Nickel-plated brass CW617N
7	Nut	1	Nickel-plated brass CW617N
8	Ring	1	Zinc-plated steel Fe
9	O-ring	1	NBR

## OVERALL DIMENSIONS

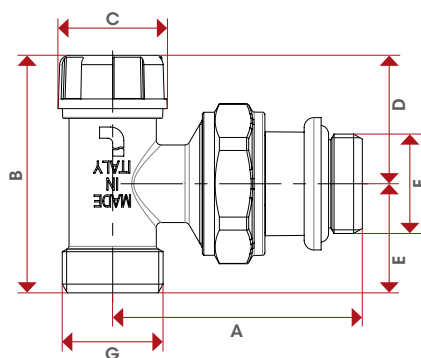

	3/8"	1/2"
DN	10	15
A	50	51,5
B	49	49
C	22,5	22,5
D	26,5	26,5
E	22,5	22,5
F	3/8"	1/2"
G	1/2"	1/2"
Kg/cm <sup>2</sup> bar	10	10
LBS - psi	145	145

994 - 995  
3/8"

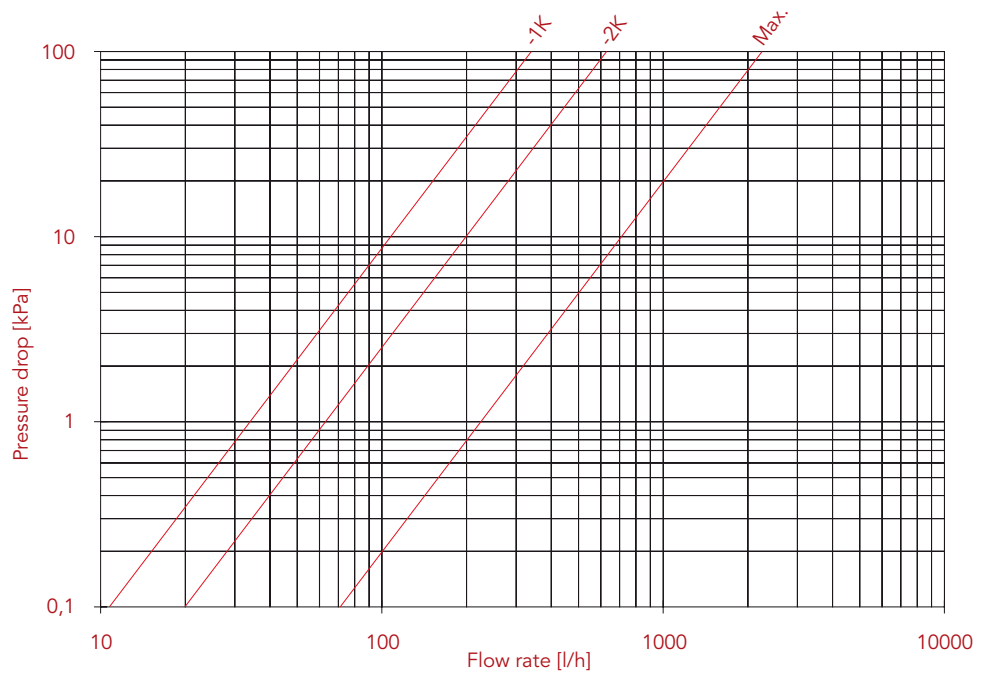
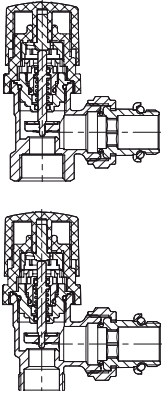

SIZE	3/8"		
-	-1K	-2K	Max
Kv	0,34	0,63	2,25

With water

994 - 995  
1/2"

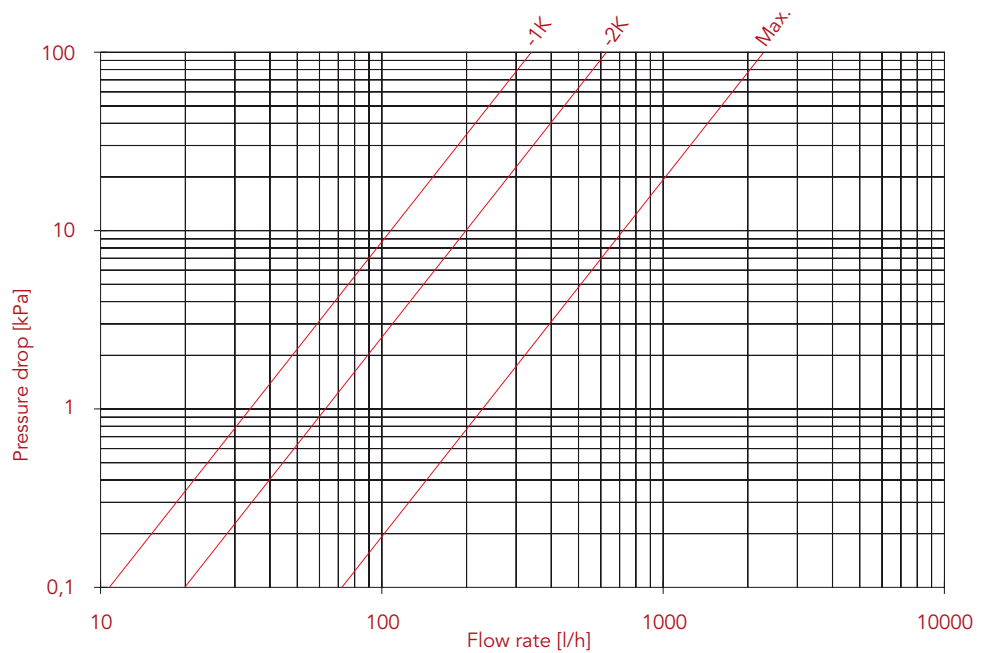
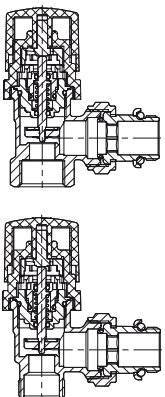

SIZE	1/2"		
-	-1K	-2K	Max
Kv	0,34	0,63	2,28

With water





994  
3/4"

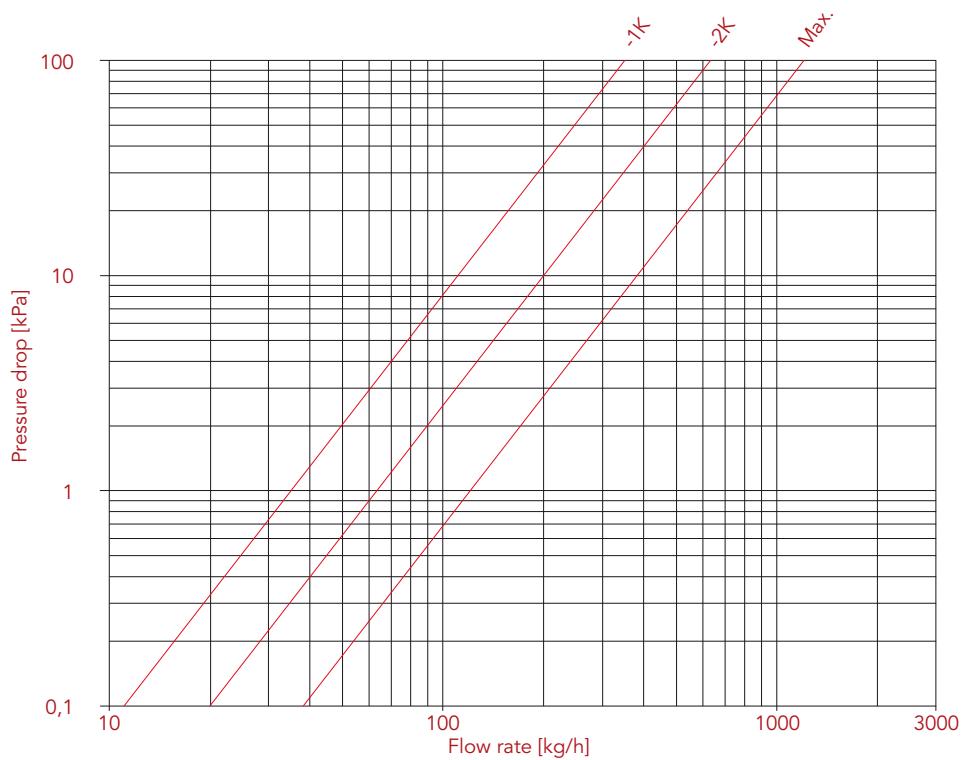
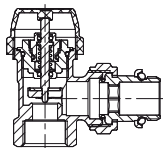

SIZE	3/4"		
-	-1K	-2K	Max
Kv	0,35	0,63	1,20

With water

## 396S - 397S 3/8"

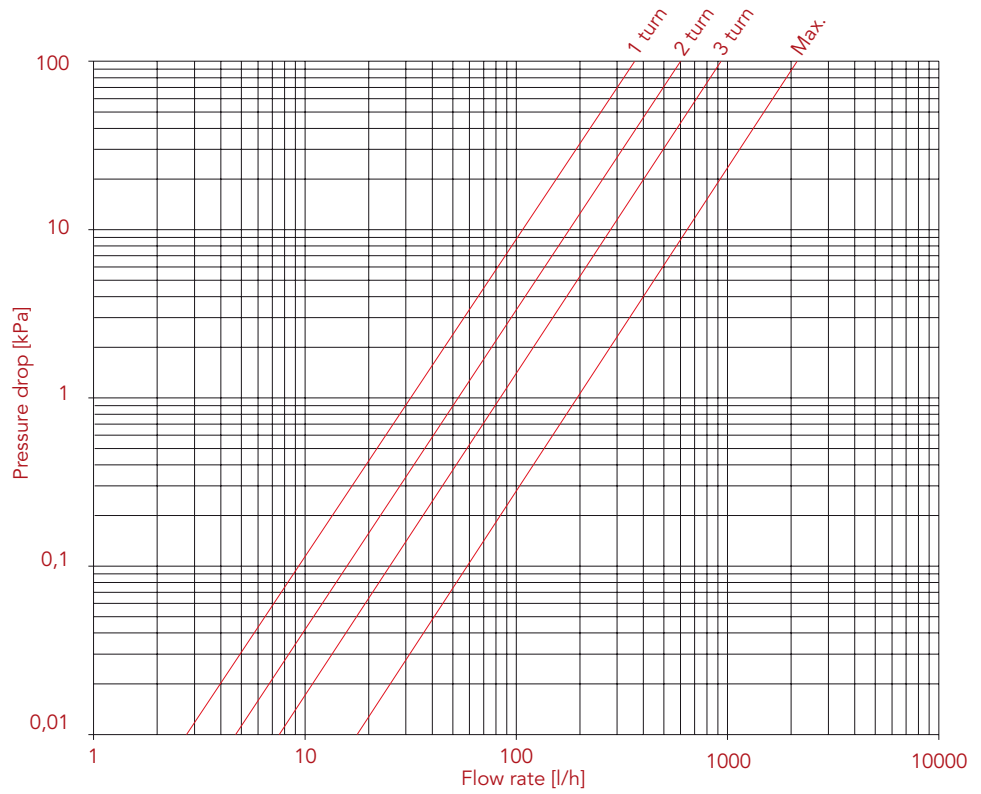
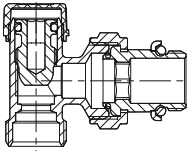
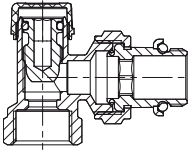

SIZE	3/8"			
Turn	1	2	3	Open
Kv	0,38	0,6	0,92	2,13

With water

## 396S - 397S 1/2"

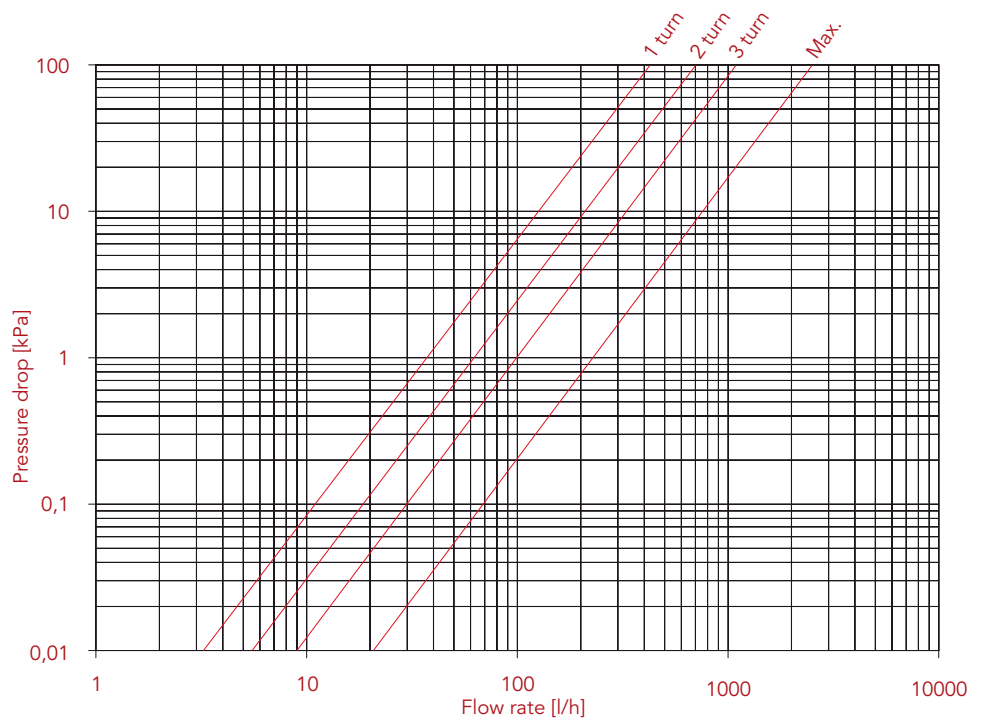
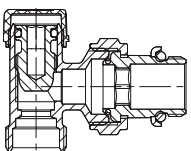
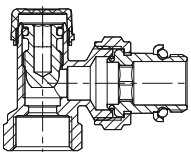

SIZE	1/2"			
Turn	1	2	3	Open
Kv	0,42	0,70	1,10	2,51

With water



396S  
3/4"

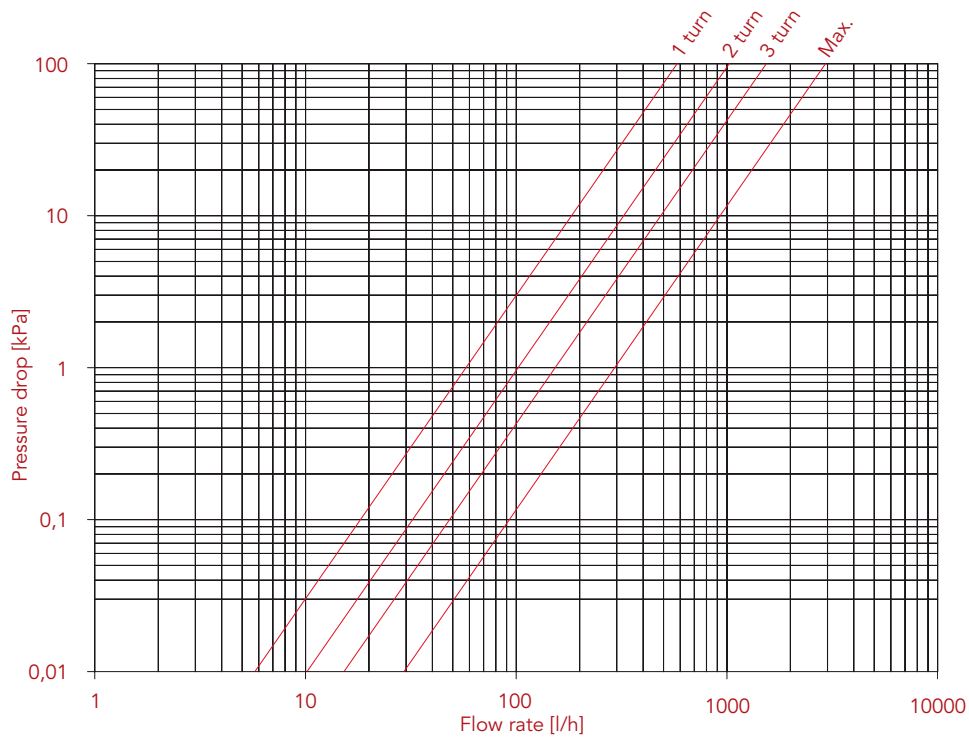
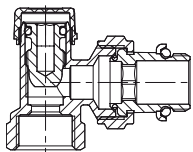

SIZE	3/4"			
Turn	1	2	3	Open
Kv	0,6	1,02	1,54	2,94

With water

# 894CPS

PRE-SETTING STRAIGHT  
CONVERTIBLE VALVE WITH  
CAP, FEMALE THREAD



SIZE	PRESSURE	CODE	PACKING
3/8" (DN 10)	10bar/145psi	8940038CPS	4/120
1/2" (DN 15)	10bar/145psi	8940012CPS	4/96
3/4" (DN 20)	10bar/145psi	8940034CPS	10/80

## MATERIALS

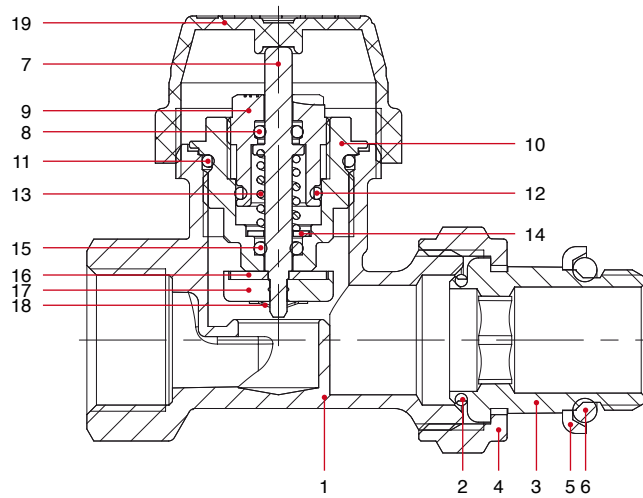

POS.	DESCRIPTION	N.	MATERIAL
1	Body	1	Nickel-plated brass CW617N
2	O-ring	1	NBR
3	Union	1	Nickel-plated brass CW617N
4	Nut	1	Nickel-plated brass CW617N
5	Ring	1	Zinc-plated steel Fe
6	O-ring	1	NBR
7	Stem	1	Brass CW614N
8	O-ring	1	EPDM
9	Ring nut	1	Brass CW614N
10	Body	1	Brass CW614N
11	O-ring	1	EPDM
12	O-ring	1	EPDM
13	Spring	1	Stainless steel AISI 302
14	Washer	1	Stainless steel AISI 304
15	O-ring	1	EPDM
16	Washer	1	Stainless steel AISI 304
17	Washer	1	EPDM
18	Seeger	1	Stainless steel AISI 304
19	Cap	1	ABS



## OVERALL DIMENSIONS

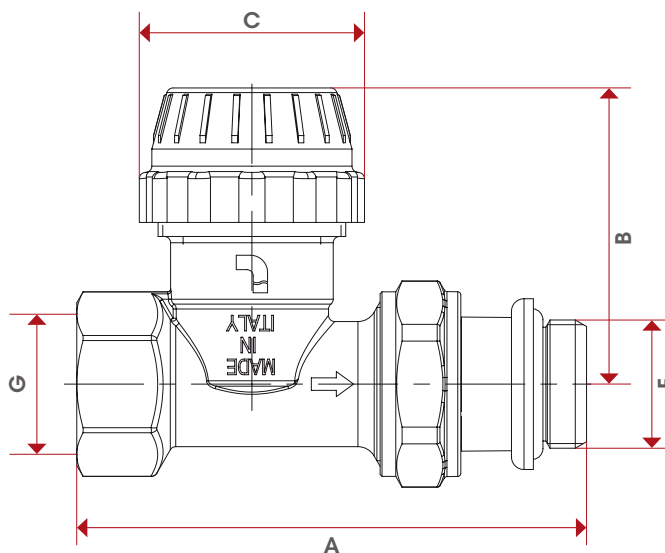

	3/8"	1/2"	3/4"
DN	10	15	20
A	75	81,5	97,5
B	47,3	47,3	43,7
C	36	36	36
F	3/8"	1/2"	3/4"
G	3/8"	1/2"	3/4"
Kg/cm <sup>2</sup> bar	10	10	10
LBS - psi	145	145	145

## CERTIFICATIONS



# 895CPS

PRE-SETTING STRAIGHT  
CONVERTIBLE VALVE  
WITH CAP,  
MALE THREAD



SIZE	PRESSURE	CODE	PACKING
3/8" (DN 10)	10bar/145psi	8950038CPS	4/120
1/2" (DN 15)	10bar/145psi	8950012CPS	4/96

## MATERIALS

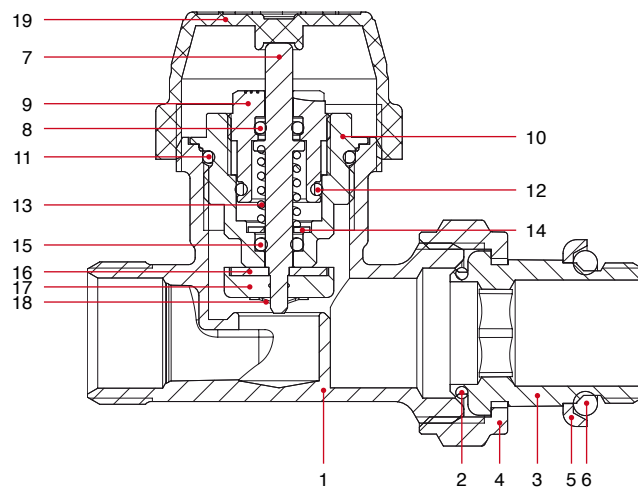

POS.	DESCRIPTION	N.	MATERIAL
1	Body	1	Nickel-plated brass CW617N
2	O-ring	1	NBR
3	Union	1	Nickel-plated brass CW617N
4	Nut	1	Nickel-plated brass CW617N
5	Ring	1	Zinc-plated steel Fe
6	O-ring	1	NBR
7	Stem	1	Brass CW614N
8	O-ring	1	EPDM
9	Ring nut	1	Brass CW614N
10	Body	1	Brass CW614N
11	O-ring	1	EPDM
12	O-ring	1	EPDM
13	Spring	1	Stainless steel AISI 302
14	Washer	1	Stainless steel AISI 304
15	O-ring	1	EPDM
16	Washer	1	Stainless steel AISI 304
17	Washer	1	EPDM
18	Seeger	1	Stainless steel AISI 304
19	Cap	1	ABS



## OVERALL DIMENSIONS

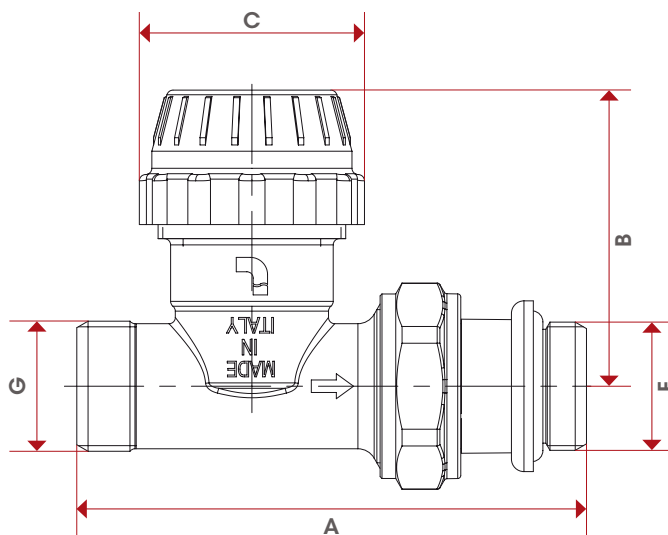

	3/8"	1/2"
DN	10	15
A	75	81,5
B	47,3	47,3
C	36	36
F	3/8"	1/2"
G	1/2"	1/2"
Kg/cm <sup>2</sup> bar	10	10
LBS - psi	145	145

## CERTIFICATIONS



# 994CPS

PRE-SETTING ANGLE  
CONVERTIBLE VALVE  
WITH CAP,  
FEMALE THREAD



SIZE	PRESSURE	CODE	PACKING
3/8" (DN 10)	10bar/145psi	9940038CPS	4/120
1/2" (DN 15)	10bar/145psi	9940012CPS	4/96
3/4" (DN 20)	10bar/145psi	9940034CPS	10/80

## MATERIALS

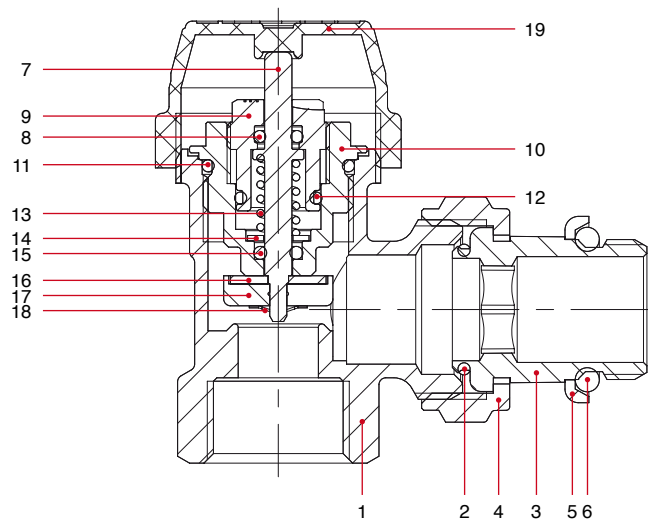

POS.	DESCRIPTION	N.	MATERIAL
1	Body	1	Nickel-plated brass CW617N
2	O-ring	1	NBR
3	Union	1	Nickel-plated brass CW617N
4	Nut	1	Nickel-plated brass CW617N
5	Ring	1	Zinc-plated steel Fe
6	O-ring	1	NBR
7	Stem	1	Brass CW614N
8	O-ring	1	EPDM
9	Ring nut	1	Brass CW614N
10	Body	1	Brass CW614N
11	O-ring	1	EPDM
12	O-ring	1	EPDM
13	Spring	1	Stainless steel AISI 302
14	Washer	1	Stainless steel AISI 304
15	O-ring	1	EPDM
16	Washer	1	Stainless steel AISI 304
17	Washer	1	EPDM
18	Seeger	1	Stainless steel AISI 304
19	Cap	1	ABS





## OVERALL DIMENSIONS

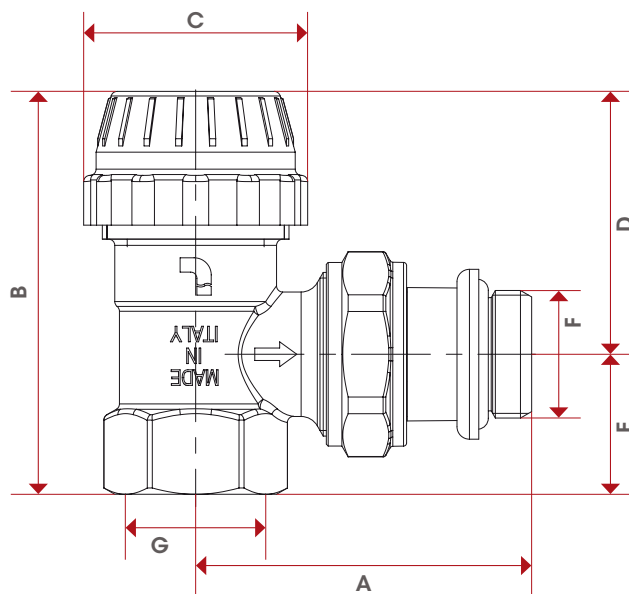

	3/8"	1/2"	3/4"
DN	10	15	20
A	49,5	54	62,5
B	62,3	64,3	59,5
C	36	36	36
D	42,2	42,2	33,5
E	20,5	22,5	26
F	3/8"	1/2"	3/4"
G	3/8"	1/2"	3/4"
Kg/cm <sup>2</sup> bar	10	10	10
LBS - psi	145	145	145

## CERTIFICATIONS



# 995CPS

PRE-SETTING ANGLE  
CONVERTIBLE VALVE  
WITH CAP,  
MALE THREAD



SIZE	PRESSURE	CODE	PACKING
3/8" (DN 10)	10bar/145psi	9950038CPS	4/120
1/2" (DN 15)	10bar/145psi	9950012CPS	4/96

## MATERIALS

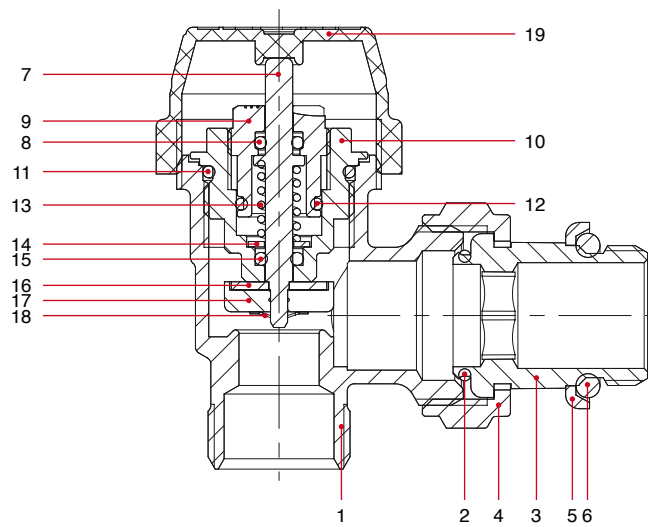

POS.	DESCRIPTION	N.	MATERIAL
1	Body	1	Nickel-plated brass CW617N
2	O-ring	1	NBR
3	Union	1	Nickel-plated brass CW617N
4	Nut	1	Nickel-plated brass CW617N
5	Ring	1	Zinc-plated steel Fe
6	O-ring	1	NBR
7	Stem	1	Brass CW614N
8	O-ring	1	EPDM
9	Ring nut	1	Brass CW614N
10	Body	1	Brass CW614N
11	O-ring	1	EPDM
12	O-ring	1	EPDM
13	Spring	1	Stainless steel AISI 302
14	Washer	1	Stainless steel AISI 304
15	O-ring	1	EPDM
16	Washer	1	Stainless steel AISI 304
17	Washer	1	EPDM
18	Seeger	1	Stainless steel AISI 304
19	Cap	1	ABS



## OVERALL DIMENSIONS

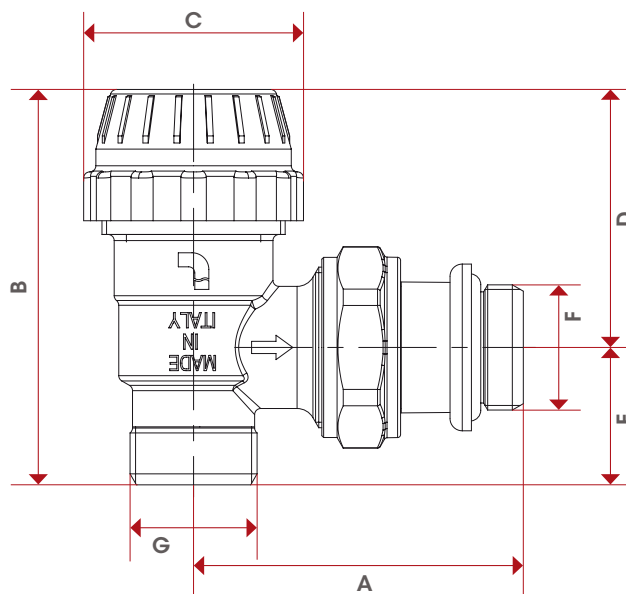

	3/8"	1/2"
DN	10	15
A	49,5	54
B	62,3	64,7
C	36	36
D	42,2	42,2
E	20,5	22,5
F	3/8"	1/2"
G	1/2"	1/2"
Kg/cm <sup>2</sup> bar	10	10
LBS - psi	145	145

## CERTIFICATIONS



894CPS  
895CPS

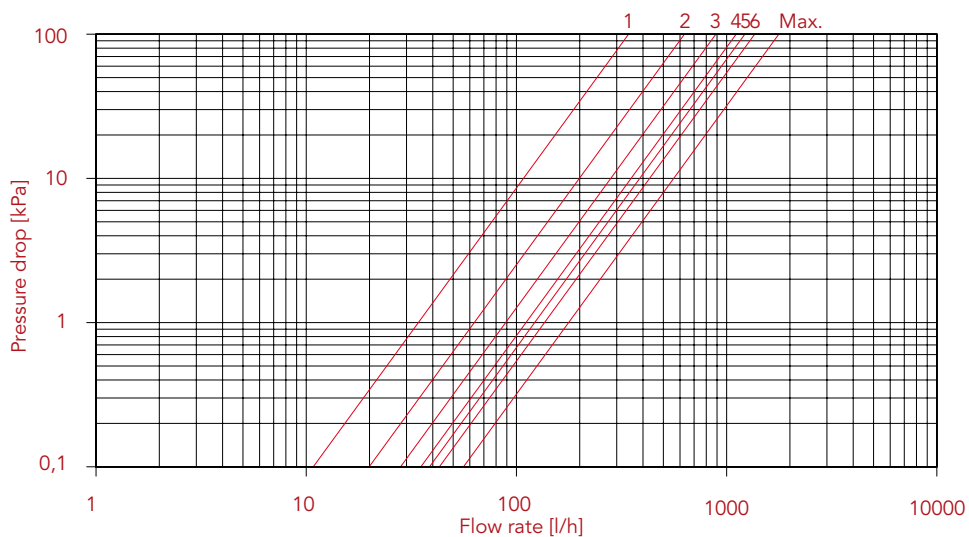
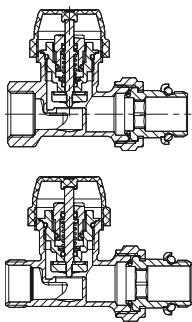

SIZE	3/8" - 1/2" - 3/4"						
Pre-setting position	1	2	3	4	5	6	Max.
Kv	0,34	0,63	0,89	1,11	1,22	1,36	1,77

With water

994CPS  
995CPS

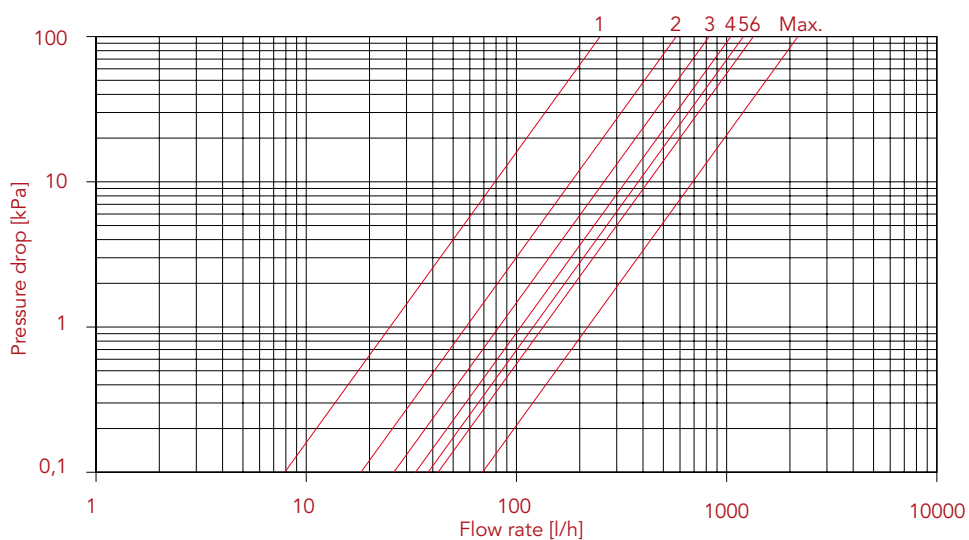
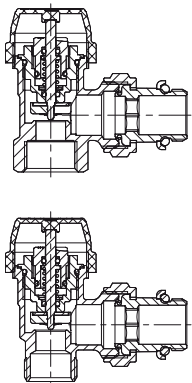

SIZE	3/8" - 1/2" - 3/4"						
Pre-setting position	1	2	3	4	5	6	Max.
Kv	0,25	0,58	0,83	1,05	1,20	1,34	2,18

With water



# PRE-SETTING REGULATION

## 3/8" - 1/2"

Turn the pre-setting screw until stop.  
Mark the position of the screw-driver slot as reference point, then turn anti-clockwise according to the above pressure drop and flow rate charts.

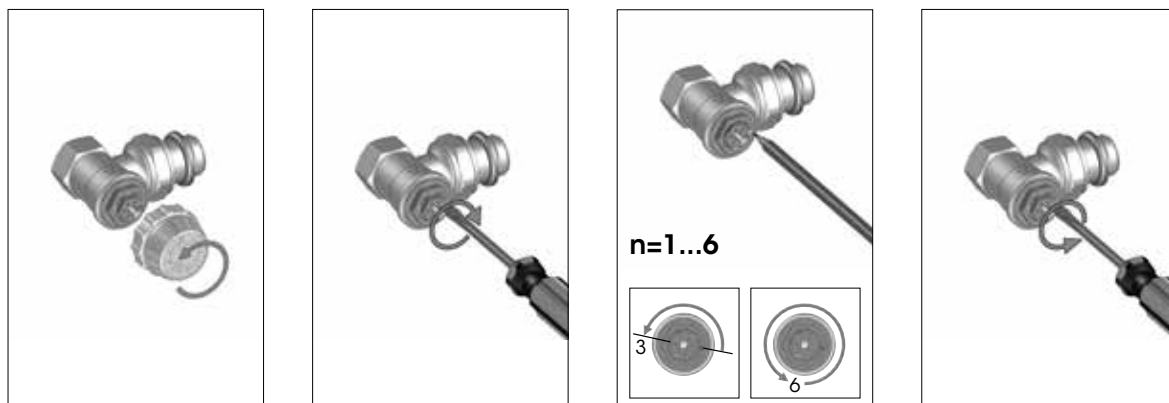

Pre-setting above 3 are unsuitable for operation with thermostatic heads and should only be used with actuators (open/close operation).

Normal flow rate according to different pre-setting positions (using the thermostatic head)  
Q<sub>ms</sub> (l/h) with Δp 10 kPa

SIZE	3/8" - 1/2"								
Pre-setting position	1	2	3	4	5	6	Max.	Q <sub>mn</sub>	
894CPS - 895CPS	108	180	210	210	210	210	210	210	
994CPS - 995CPS	90	180	210	210	210	210	210	210	
±%	60	30	20	10	10	10	10	10	

## 3/4"

Use a wrench (13 mm) to set the index on one of the numbers (the selector cannot be positioned between two numbers)

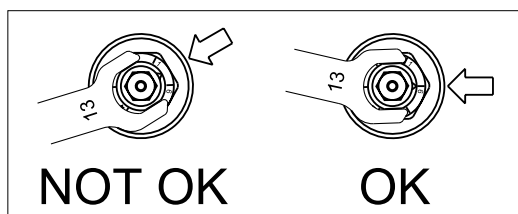

Normal flow rate according to different pre-setting positions (using the thermostatic head)  
Q<sub>ms</sub> (l/h) with Δp 10 kPa

SIZE	3/4"					
Pre-setting position	1	2	3	4	5	6
894CPS	30	60	95	130	210	270
994CPS	30	60	95	130	210	305
±%	60	30	20	10	10	10

# 891

THERMOSTATIC  
CONTROL HEAD WITH  
OIL-FILLED ELEMENT



CODE	891
PACKING	1/100

## TECHNICAL SPECIFICATIONS

- Scale values: \* to 5.
- Adjustable temperature range: 6,5°C, 28°C.
- Antifreeze position set: 6,5°C.
- Device to restrict or lock temperature setting included.
- Hysteresis: 0,5K.
- Water temperature effect (W): 0,75K.
- Response time: (Z): 30min.
- Maximum differential pressure: 1,5bar.

# 891SD

THERMOSTATIC  
CONTROL HEAD WITH  
REMOTE CONTROL



CODE	891SD
PACKING	1/32

## TECHNICAL SPECIFICATIONS

- Scale values: \* to 5.
- Adjustable temperature range: 6,5°C, 28°C.
- Antifreeze position set: 6,5°C.
- Device to restrict or lock temperature setting included.
- Hysteresis: 0,5K.
- Maximum differential pressure: 1,5bar.
- Length of the capillary pipe: 2 m.

# 891GA

TAMPER-PROOF CAP  
FOR THERMOSTATIC  
CONTROL HEADS



CODE	891GA
PACKING	75/600

## TECHNICAL SPECIFICATIONS

Available for thermostatic control heads art. 891 e art. 891SD.



# 891

OVERALL DIMENSIONS

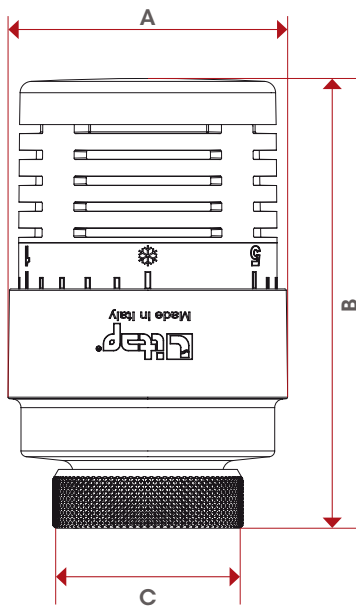

A	48,5
B	78
C	M30x1,5

# 891SD

OVERALL DIMENSIONS

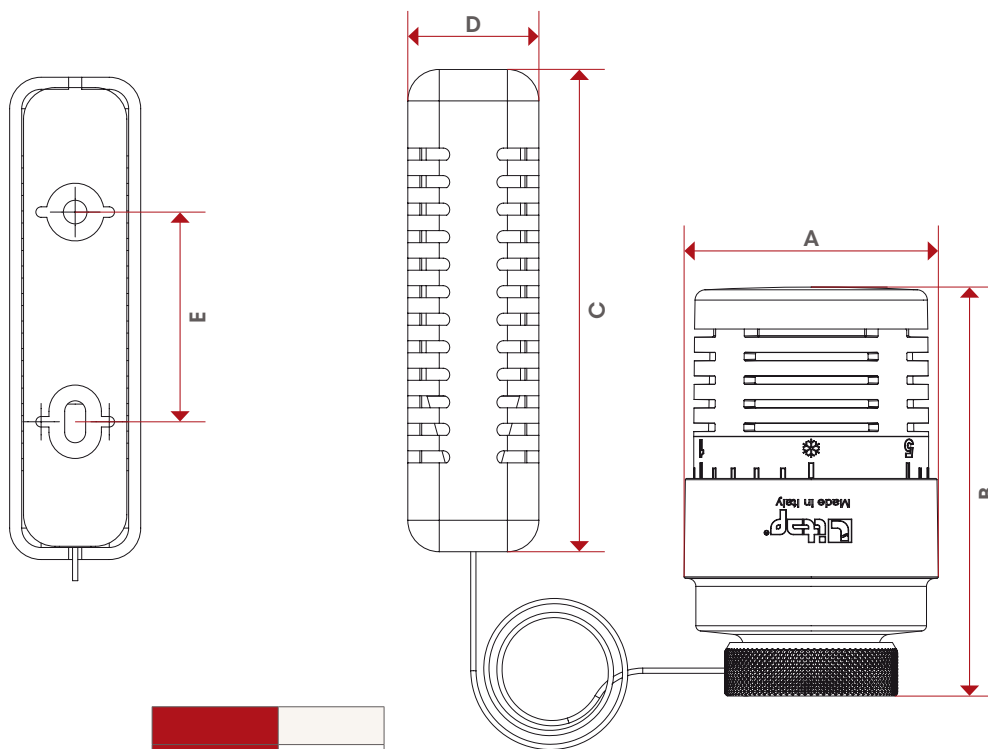

A	48,5
B	78
C	92
D	25
E	40

# 891GA

OVERALL DIMENSIONS

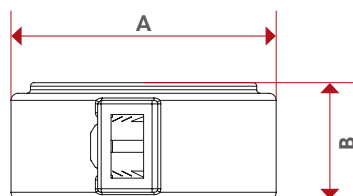

A	37,5
B	16,5

# INSTALLATION

Convertible valves can be coupled to thermostatic control heads by a simple operation. This conversion into thermostatic valve can be implemented even in a working installation.



1. Remove the handle.
2. Rotate the thermostatic control head to full open (position 5).
3. Draw the control head close to the valve keeping the reference index fully visible, then manually screw the nickel-plated ring all the way to the blocking point. Do not position the control head vertically.

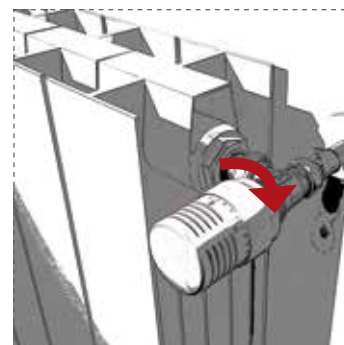
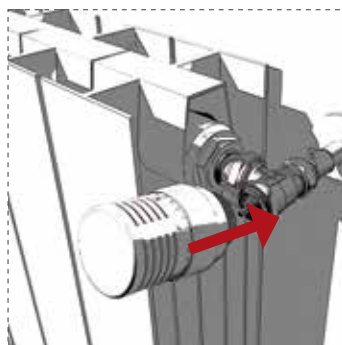
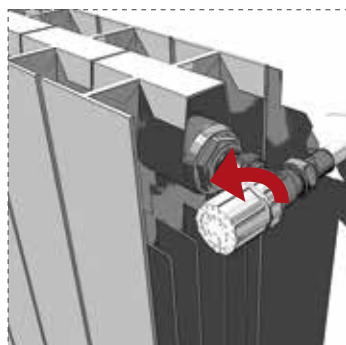

To prevent the thermostatic control head from working incorrectly, tending to mainly keep the value closed, you need to respect a few precautions.

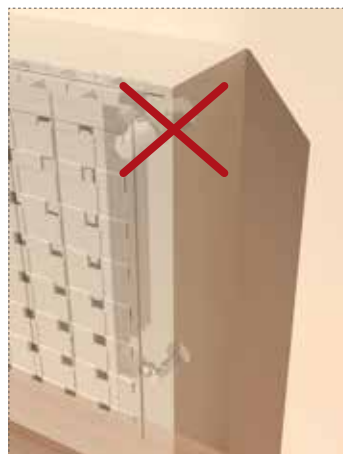



The sensitive element of the thermostatic head must not be placed in niches, or behind curtains, or exposed to direct sunlight: each of these situations may give a false reading. Should it be unable to avoid curtains or any of the aforementioned situations described, you are required to install a head with remote control (Art. 891SD).

Refer to the numbers indicated on the control knob to set the room temperature. Each number (from \* to 5) may be used for a specific room temperature, as indicated in the following diagram (closed at 28°C):

	1	2	3	4	5
6,5°C Min	12°C	16°C	20°C	24°C	28°C Max



## THERMOSTATIC HEAD SETTING

Set the head in the required position ex.(3).

- Use a screwdriver to disassemble the cover (b), the locking cap (c) and the first of the toothed washer (d) FIG. II.

- Reassemble the washer (d) as in FIG. III if you want to limit the setting from \* to 3.

- Reassemble the washer (d) as in FIG IV if you want to block the setting at the value of 3.

- Then reassemble the locking cap (c) and the cover (b).

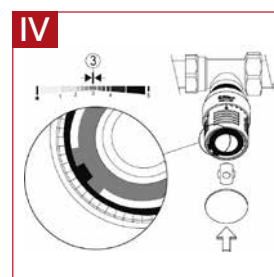
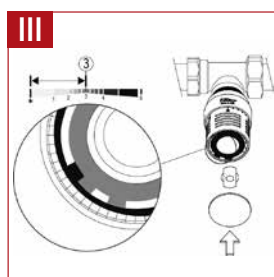
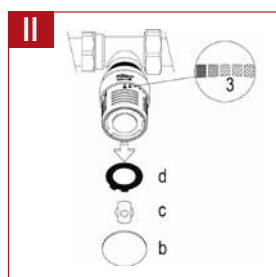
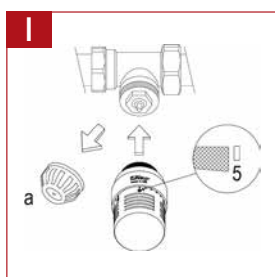



# NOTES

A series of horizontal dashed lines for taking notes, extending from the 'NOTES' header across the page.



ITAP S.p.A.  
Via Ruca 19  
25065 Lumezzane  
Brescia (ITALIA)  
Tel 030 89270  
Fax 030 8921990  
[www.itap.it](http://www.itap.it)  
[info@itap.it](mailto:info@itap.it)