



Application:

The Oventrop boiler connection system “Regumat-180” DN 25 - pump length 180 mm - allows for a time-, cost- and space-saving connection of the boiler to the pipework. The “Regumat-180” stations are available with or without high-efficiency pumps.

Advantages:

- pre-assembled connection system for pumps with a length of 180 mm
- high quality materials
- universal thermal insulation of modular construction supplied with each “Regumat”
- easy installation by use of tailpipe sets
- no hemp sealing
- supply and return pipe can be changed on site

Choice of the “Regumat-180” stations:

Product assembly DN 25 for pump length 180 mm

The “Regumat-180” without pump ball valve is available with or without high-efficiency pump

- as basic model (without mixing valve)
- as model with three- or four-way mixing valve with bypass with manual presetting and actuator

The “Regumat” can be upgraded with a pressure relief device.

Dimensions: H = 414 mm, W = 248 mm, D = 200 mm



“Regumat M3-180” DN 25

	Model <u>without</u> mixing valve	Model <u>with</u> mixing valve	
	“Regumat S-180”	“Regumat M3-180”	“Regumat M4-180”
Isolation device with 2 ball valves and 2 thermometers (without pressure relief device)	X	X	X
Flanged pipe with check valve	X	X	X
Three-way mixing valve with actuator (suitable for standard boiler regulations)		X	
Four-way mixing valve with actuator (suitable for standard boiler regulations)			X
Distance piece	X		
Thermal insulation	X	X	X

Tailpipe sets are available as accessories.

Tender specification: "Regumat S-180" DN 25 - constant temperature heating circuit

Product assembly for the connection of the boiler to the pipework.

Consisting of: Isolation device with 2 ball valves for the isolation of the heating circuit, 2 thermometers integrated in the handles of the ball valves for flow and return temperature display, flanged pipe with check valve in the return pipe to avoid gravity circulation as well as universal thermal insulation of modular construction.

Ball valves: Body and stem made of brass with double O-ring seal.
Hard-chrome plated brass balls, PTFE seats, brass collar nuts.
Thermometers integrated in the handles, with position indicator "full flow" respectively "closed".

Connection: To boiler and heating circuit G 1½ flat sealing male thread, without collar nuts for tailpipe sets

Technical data:

Nominal size:	DN 25
Max. operating temperature:	95 °C
Max. operating pressure:	10 bar
Temperature measuring range:	0 °C up to 120 °C
Opening pressure check valve:	20 mbar
k _{vS} value:	7.4

Pump connection: for pumps with G 1½ male thread, pump length 180 mm

Distance between supply and return pipe: 125 mm

Note: On delivery, the supply pipe is on the right hand side. If required, the supply and the return pipe can be changed on site (see installation instructions).

Models:

without high-efficiency pump	Item no.: 1356020
with high-efficiency pump (EEI ≤ 0.2)	
Grundfos ALPHA 2.1 25-60	1356077
Wilo-Stratos PICO 25/1-6	1356079

Function:

The station "Regumat S-180" for the isolation of the heating circuit consists of an isolation device with thermometers integrated in the handles of the ball valves and a distance piece for length compensation in the supply pipe. If required, the "Regumat" can be upgraded with a pressure relief device.

The flanged pipe with check valve integrated in the return pipe avoids gravity circulation.

Note:

When the high-efficiency pump is switched off, a low gravity circulation depending on the circulation pressure is still possible within the heating system as the check valve is not tight sealing.

To avoid malfunctions caused by impurities, the installation of an Oventrop strainer is recommended. The installation has to be flushed thoroughly before commissioning.

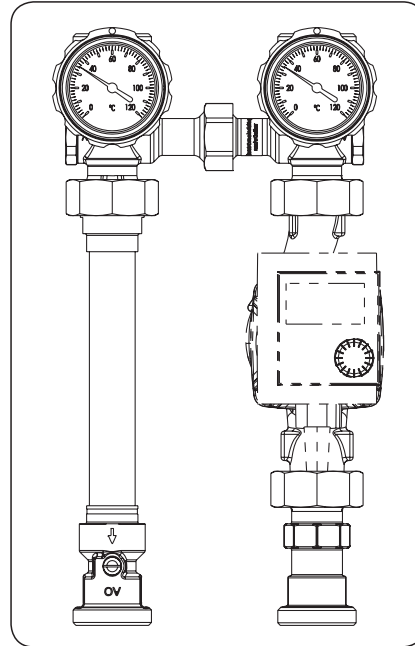

"Regumat S-180"

Tender specification: “Regumat M3-180” DN 25 - variable temperature heating circuit

Product assembly for the connection of the boiler to the pipework.

Consisting of: Isolation device with 2 ball valves for the isolation of the heating circuit, 2 thermometers integrated in the handles of the ball valves for flow and return temperature display, flanged pipe with check valve in the return pipe to avoid gravity circulation, three-way mixing valve with bypass with manual presetting and mounted actuator for flow temperature control as well as universal thermal insulation of modular construction.

Ball valves: Body and stem made of brass with double O-ring seal. Hard-chrome plated brass balls, PTFE seats, brass collar nuts. Thermometers integrated in the handles, with position indicator “full flow” respectively “closed”.

Three-way mixing valve: With bypass with manual presetting, body and regulating insert made of brass, shaft of mixing valve with double O-ring seal

Connection: To boiler and heating circuit G 1½ flat sealing male thread, without collar nuts for tailpipe sets

Technical data:

Nominal size: DN 25
Max. operating temperature: 95 °C
Max. operating pressure: 10 bar
Temperature measuring range: 0 °C up to 120 °C
Opening pressure check valve: 20 mbar
k_{vs} value: 4.3

Pump connection: for pumps with G 1½ male thread, pump length 180 mm

Actuator: Voltage 230 V
Operating time for 90° angle: 140 seconds
Cable 2.2 meter long

Distance between supply and return pipe: 125 mm

Note: On delivery, the supply pipe is on the right hand side. If required, the supply and the return pipe can be changed on site (see installation instructions).

Models:	Item no.:
without high-efficiency pump	1356220
with high-efficiency pump (EEI ≤ 0.2)	
Grundfos ALPHA 2.1 25-60	1356277
Wilo-Stratos PICO 25/1-6	1356279
without high-efficiency pump and without actuator	1656223

Function:

The “Regumat M3-180” has the same design and function as the “Regumat S-180”. It is additionally equipped with a three-way mixing valve with mounted actuator. The three-way mixing valve serves to regulate the flow temperature and has a bypass with manual presetting. A manually set return flow share can be added to the supply pipe via this bypass in order to reduce the temperature of a surface heating for instance.

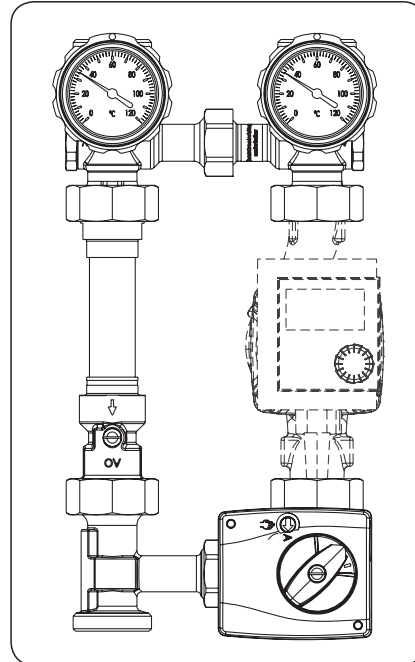

“Regumat M3-180”



Tender specification: "Regumat M4-180" DN 25 - variable temperature heating circuit

Product assembly for the connection of the boiler to the pipework.

Consisting of: Isolation device with 2 ball valves for the isolation of the heating circuit, 2 thermometers integrated in the handles of the ball valves for flow and return temperature display, flanged pipe with check valve in the return pipe to avoid gravity circulation, four-way mixing valve with bypass with manual presetting and mounted actuator for flow temperature control as well as universal thermal insulation of modular construction. The station is supplied without high-efficiency pump.

Ball valves: Body and stem made of brass with double O-ring seal.
Hard-chrome plated brass balls, PTFE seats, brass collar nuts.
Thermometers integrated in the handles, with position indicator "full flow" respectively "closed".

Four-way mixing valve: With bypass with manual presetting, body made of bronze, regulating insert made of brass, shaft of mixing valve with double O-ring seal

Connection: To boiler and heating circuit G 1½ flat sealing male thread, without collar nuts for tailpipe sets

Technical data:

Nominal size: DN 25
Max. operating temperature: 95 °C
Max. operating pressure: 10 bar
Temperature measuring range: 0 °C up to 120 °C
Opening pressure check valve: 20 mbar
k_{VS} value: 4.2

Pump connection: for pumps with G 1½ male thread, pump length 180 mm

Actuator: Voltage 230 V
Operating time for 90° angle: 140 seconds
Cable 2.2 meter long

Distance between supply and return pipe: 125 mm

Note: On delivery, the supply pipe is on the right hand side. If required, the supply and the return pipe can be changed on site (see installation instructions).

Model:
without high-efficiency pump

Item no.:
1356420

Function:

The "Regumat M4-180" has the same design and function as the "Regumat S-180". It is additionally equipped with a bronze four-way mixing valve with mounted actuator. The four-way mixing valve serves to regulate the flow temperature. The return temperature of the boiler is increased at the same time. The bypass with manual presetting in the mixing valve serves to regulate the flow temperature in systems with a high boiler temperature and a low flow temperature (such as surface heating systems). This bypass constantly adds return water to the supply pipe.

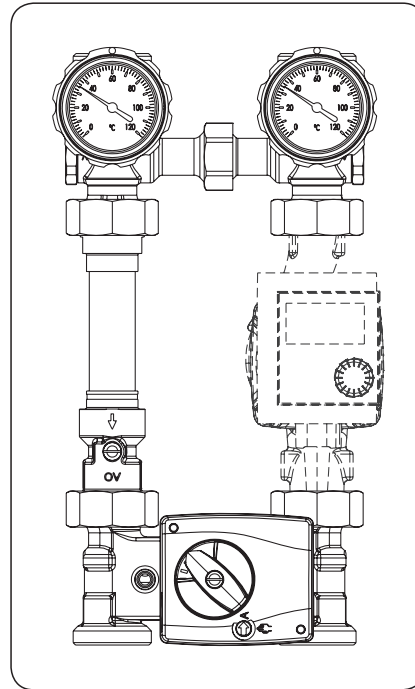

"Regumat M4-180"

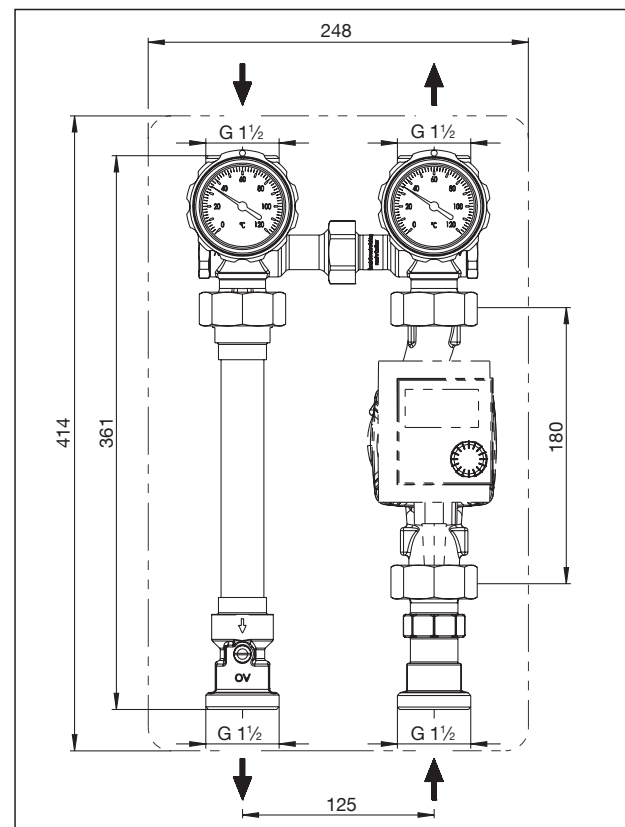

Dimensions "Regumat S-180" without pump ball valve at the pump inlet

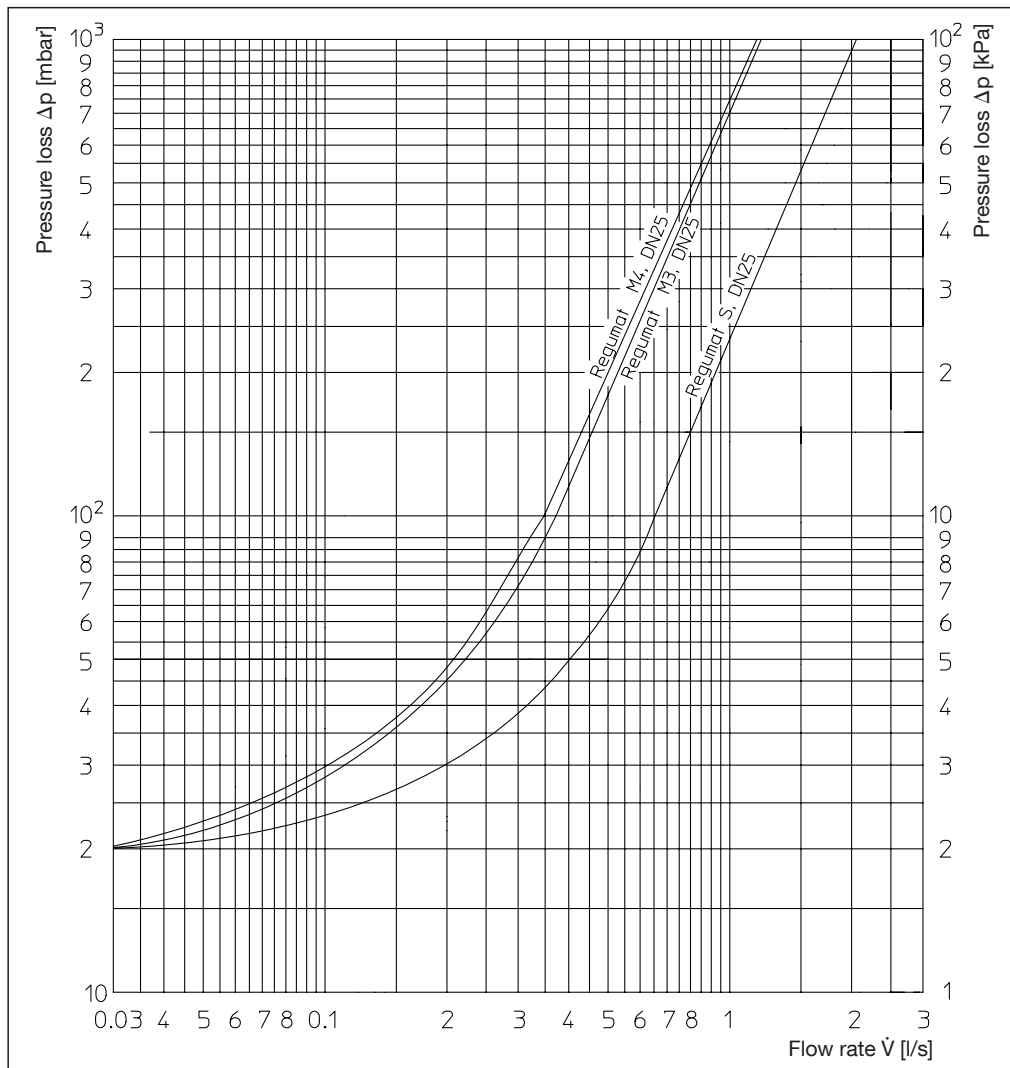

Flow chart "Regumat-180"

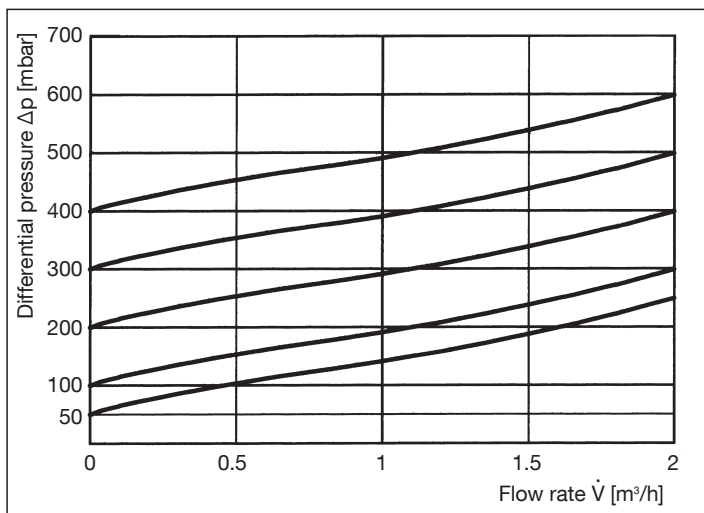

Flow chart bypass (pressure relief device)



Wall mounting device:

For mounting the "Regumat" DN 25 onto the wall, a wall mounting device, item no. 1352096, is available.

Tailpipe sets are available as accessories.

Subject to technical modifications without notice. .

Product range 6
ti 175-EN/10/MW
Edition 2017