

Application:

The Oventrop boiler connection system "Regumat-180" DN 25 - pump length 180 mm - allows for a time-, cost- and space-saving connection of the boiler to the pipework. The "Regumat-180" stations are available with or without high-efficiency pumps.

Advantages:

- pre-assembled connection system for pumps with a length of 180 mm
- high quality materials
- universal thermal insulation of modular construction supplied with each "Regumat"
- return pipe with check valve which can be opened manually
- easy installation by use of tailpipe sets
- no hemp sealing
- integrated wall mounting device
- supply and return pipe can be changed on site
- actuator with quick mounting technique "plug & play"



"Regumat M3-180" DN 25

Choice of the "Regumat-180" stations:

Product assembly DN 25 for pump length 180 mm

The "Regumat-180" without pump ball valve is available with or without high-efficiency pump

- as basic model (without mixing valve)
 - as model with three-mixing valve with check valve and actuator
- The actuator can be mounted without tools - "plug & play".

Dimensions H = 393 mm, W = 248 mm, D = 213 mm

	Model <u>without</u> mixing valve	Model <u>with</u> mixing valve
	"Regumat S-180"	"Regumat M3-180"
Isolation device with 2 ball valves and 2 thermometers (without pressure relief device)	X	X
Wall mounting device	X	X
Return pipe with check valve	X	
Three-way mixing valve with check valve and actuator (suitable for standard boiler regulations)		X
Pump ball valve at the pump inlet	X	
Thermal insulation	X	X

Tailpipe sets are available as accessories.

Tender specification: "Regumat S-180" DN 25 - constant temperature heating circuit

Product assembly for the connection of the boiler to the pipework.

Consisting of: Isolation device with 2 ball valves for the isolation of the heating circuit, 2 thermometers integrated in the handles of the ball valves for flow and return temperature display, 1 pump ball valve at the pump inlet, return pipe with integrated check valve to avoid gravity circulation as well as universal thermal insulation of modular construction.

Materials:

Valves and fittings: Brass
Seals: EPDM

Connections:

To heating circuit: G 1½ male thread, flat sealing
To boiler: G 1½ male thread, flat sealing
Pump: G 1½ male thread, flat sealing

Technical data:

Nominal size: DN 25
Max. operating pressure: 10 bar (PN10)
Max. operating temperature: 95 °C
Opening pressure check valve: 20 mbar
K_{vs} value: 7
Recommended application range: max. 50 kW
($\Delta T = 20 \text{ K}$, $\Delta p = 100 \text{ mbar}$)

Models:

	Item no.:
without high-efficiency pump	1357020
with high-efficiency pump (EEI ≤ 0.2)	
Grundfos ALPHA 2.1 25-60	1357027
Wilo-Stratos PICO 25/1-6	1357029

Function:

The station allows for the isolation of the supply and return pipe of the heating circuit. The check valve integrated in the return pipe avoids gravity circulation.

Note:

When the high-efficiency pump is switched off, a low gravity circulation depending on the circulation pressure is still possible within the heating system as the check valve is not tight sealing. On delivery, the supply pipe is on the right hand side. If required, the supply and the return pipe can be changed on site (see installation instructions).

To avoid malfunctions caused by impurities, the installation of an Oventrop strainer is recommended. The installation has to be flushed thoroughly before commissioning.

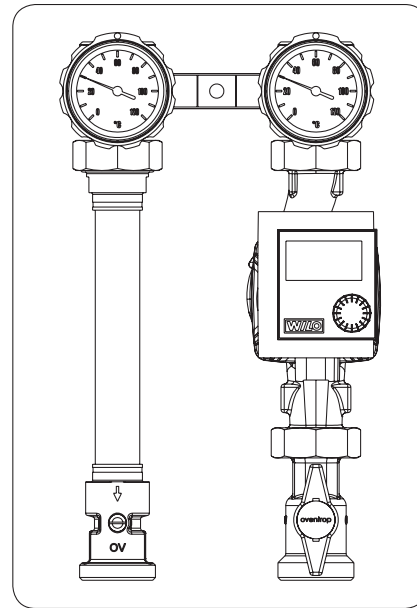

"Regumat S-180"

Tender specification: "Regumat M3-180" DN 25 - variable temperature heating circuit

Product assembly for the connection of the boiler to the pipework.

Consisting of: Isolation device with 2 ball valves for the isolation of the heating circuit, 2 thermometers integrated in the handles of the ball valves for flow and return temperature display, three-way mixing valve with check valve and mounted actuator as well as universal thermal insulation of modular construction. The actuator can be mounted without tools - "plug and play".

Materials:

Valves and fittings: Brass
Seals: EPDM

Connections:

To heating circuit: G 1½ male thread, flat sealing
To boiler: G 1½ male thread, flat sealing
Pump: G 1½ male thread, flat sealing

Technical data:

Nominal size: DN 25
Max. operating pressure: 10 bar (PN10)
Max. operating temperature: 95 °C
Opening pressure check valve: 20 mbar
Actuator: 230 V, 90°/140 sec., 5 Nm
K_{vs} value: 5.5
Recommended application range: max. 40 kW
($\Delta T = 20 \text{ K}$, $\Delta p = 100 \text{ mbar}$)

Models

	Item no.:
without high-efficiency pump	1357220
with high-efficiency pump (EEI ≤ 0.2)	
Grundfos ALPHA 2.1 25-60	1357227
Wilo-Stratos PICO 25/1-6	1357229

Function:

The "Regumat M3-180" has the same design and function as the "Regumat S-180". It is additionally equipped with a three-way mixing valve with check valve and actuator. The three-way mixing valve serves to control the flow temperature.

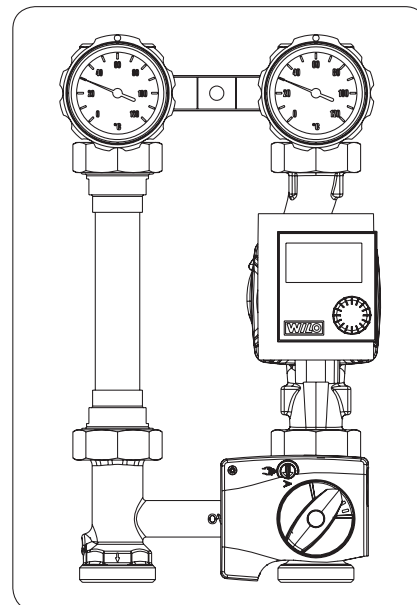

"Regumat M3-180"

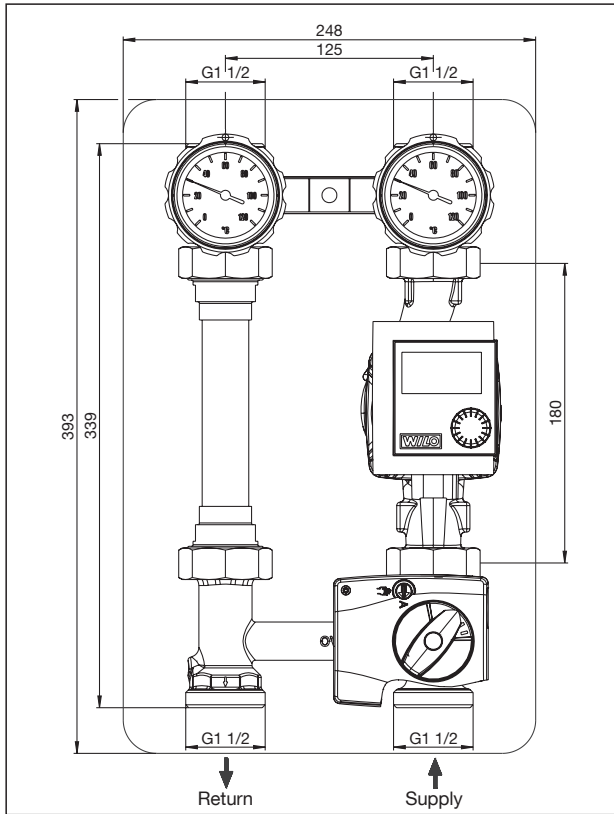

Dimensions "Regumat 180" DN 25

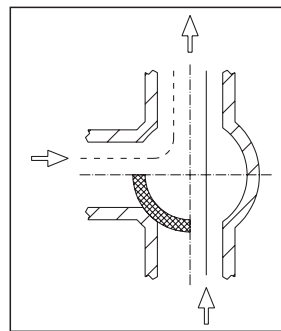
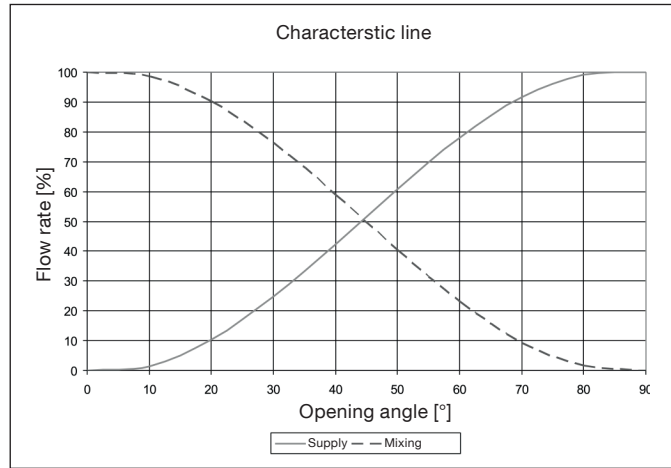

Mixing of the volume flow is achieved by a rotation of the spindle of the mixing valve.

- The equal percentage characteristic line of the mixing valve allows for a mixing of the volume flow to equal proportions
- Increased control accuracy
- Oscillation of the system is avoided
- More efficient partial load behaviour

Mixing function principle

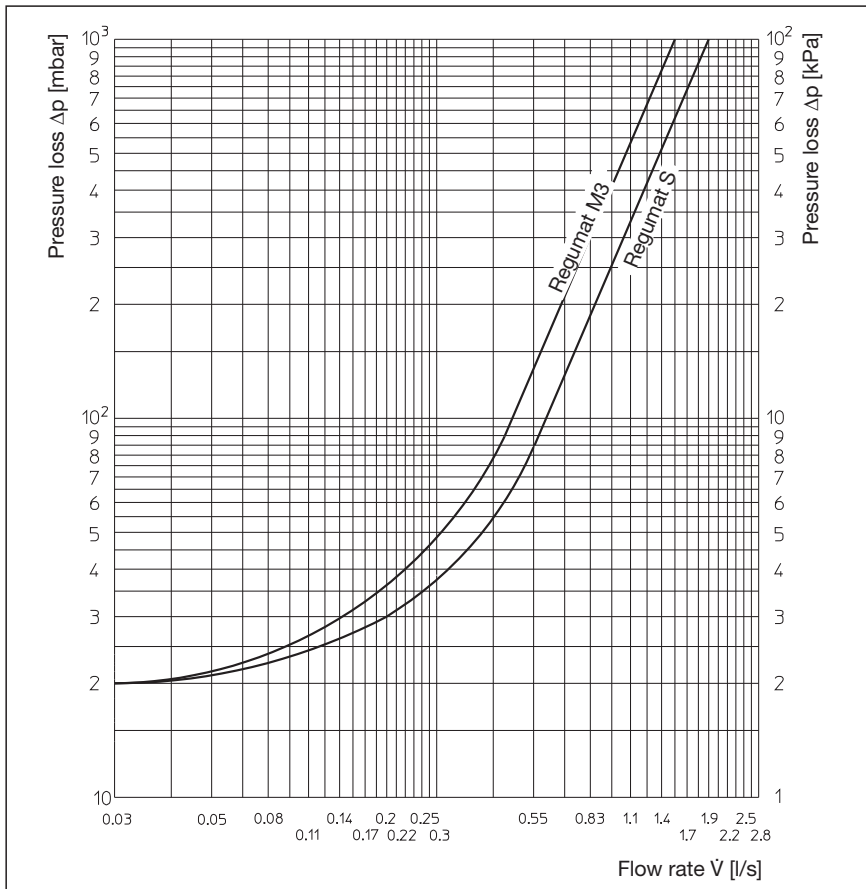

Flow chart

Tailpipe sets and a heating circuit controller extension set are available as accessories.

Subject to technical modifications without notice.

Product range 6
ti 347-EN/10/MW
Edition 2017