

R-200/11-R Ratchet Assembly

NOTE: Order parts by Catalog Number only.
DO NOT order by Reference Number.

Ref. No.	Catalog No.	Description
—	37777	Ratchet & Handle Assembly
1	38585	Handle
2	39177	Ratchet Assembly
3	39197	Knob
4	39182	Ratchet Housing
5	39172	Spring - Housing
6	39187	Ratchet Ring
7	38830	Spring - Ratchet Ring
8	39192	Pawl
9	39202	Pawl Spring

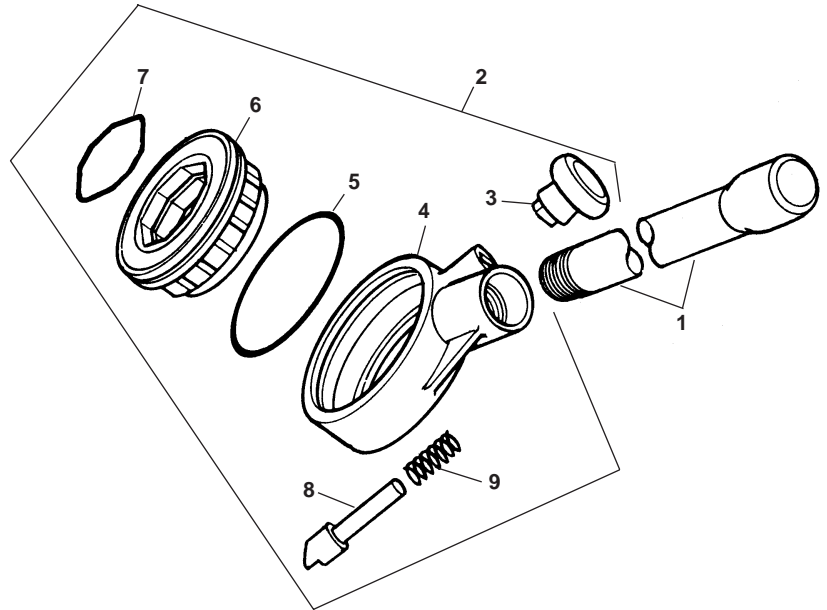

Die Head Assembly

Ref. No.	Description	11-R Catalog No.
1	Die Head w/Cover Plate & Screws	1/8"
		1/4"
		3/8"
		1/2"
		3/4"
		1" NPT/NPSM
		1" BSPT/BSPP
		1 1/4" NPT/NPSM
		1 1/4" BSPT/BSPP
		1 1/2"
		2
		16mm ISO
		20mm ISO
		25mm ISO
		32mm ISO
40mm ISO		
2	Cover Plate Screw (4)	1/8"-1/4"
		3/8"-1 1/4"
		1 1/2"-2"
		16mm - 40mm
3	Cover Plate	1/8"
		1/4"
		3/8"
		1/2"
		3/4"
		1"
		1 1/4"
		1 1/2"
		2

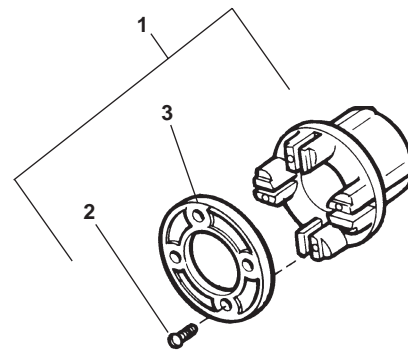

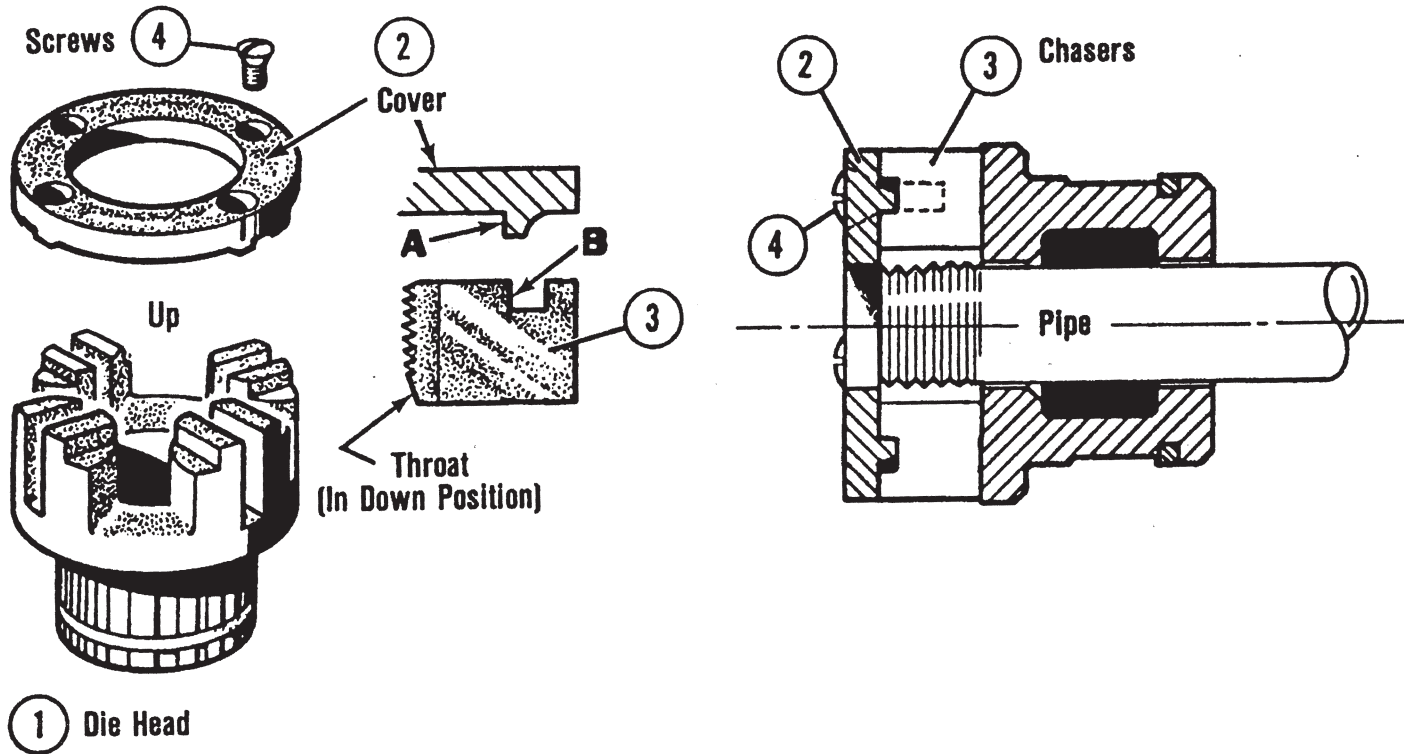

To properly insert new chasers in RIDGID Drop Head Threaders, read the following instructions carefully.

1. Place the Die Head in the position shown at left above.
2. Remove Screws (4), Cover (2), and old Chasers.
3. Insert new Chasers, throats down as shown, into Die Head slots. Numbers on Chasers must agree with those next to Die Head slots.

4. Replace Cover (2), and Screws (4). Tighten the Screws lightly.
5. Slide Die Head on already threaded nipple or pipe, until Chasers begin to thread. This forces Chasers outward against Lugs on Cover Plate. Tighten the 4 Screws securely. The Chasers are set for accurate threading by bringing **B** of Chasers against **A** of the Cover. This is the **Key** to inserting the Chasers properly.

Exposed Ratchet Type

No. 00-R

Capacity: 1/8" through 1"

No. 111-R

Capacity: 1/8" through 1 1/4"

No. 12-R

Capacity: 1/8" through 2"

No. 12-R IMC

Capacity: 1/2" through 2"

NOTE: Order parts by Catalog Number only.
DO NOT order by Reference Number.

Ref. No.	Description	00-R Catalog No.	111-R Catalog No.	12-R Catalog No.
—	Ratchet and Handle Assembly	38540	38550	38555
1	Ratchet Assembly	38565	38575	38580
2	Handle	38590	38585	38585
3	Pin	38705	38705	38705
4	Knob	38700	38700	38700
5	Spring	38695	38695	38695
6	Pawl	38690	38690	38690

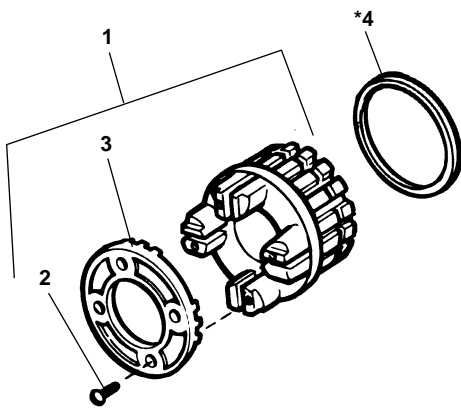
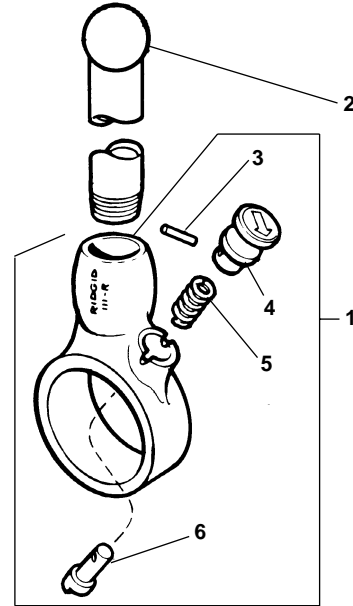

* Used on early models



Ref. No.	Description	00-R Catalog No.	111-R Catalog No.	12-R Catalog No.	12-R IMC Catalog No.
1	Die Head w/Cover Plate & Screws	1/8"	38710	38840	38890
		1/4"	38730	38850	38900
		3/8"	38740	38855	38905
		1/2"	38755	38860	38910
		3/4"	38765	38865	38915
		1"	38775	38870	38920
		1 1/4"	—	38875	38925
		1 1/2"	—	—	38930
2"	—	—	38945		
2	Cover Plate Screw (4)	1/8"-1/4"	38720	38720	38720
		3/8"-1 1/4"	38750	38750	38750
		1 1/2"-2"	—	—	38940
		—	—	—	—
3	Cover Plate	1/8"	38715	38715	38715
		1/4"	38735	38735	38735
		3/8"	38745	38745	38745
		1/2"	38760	38760	38760
		3/4"	38770	38770	38770
		1"	38780	38780	38780
		1 1/4"	—	38880	38880
		1 1/2"	—	—	38935
		2"	—	—	38950
4	Spring Ring	*38725	*38845	*38895	—

Exposed Ratchet Type

No. 00-R

Capacity: 1/8" through 1"

No. 111-R

Capacity: 1/8" through 1 1/4"

No. 12-R

Capacity: 1/8" through 2"

No. 12-R IMC

Capacity: 1/2" through 2"

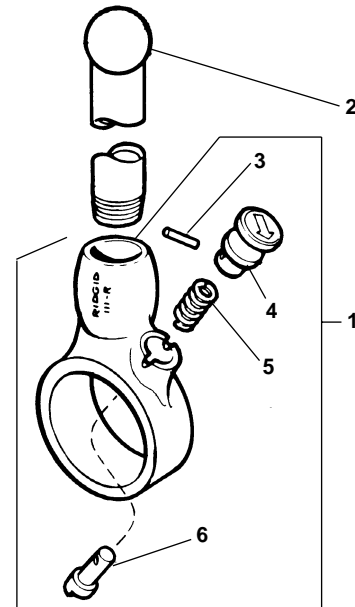

NOTE: Order parts by Catalog Number only.
DO NOT order by Reference Number.

Ref. No.	Description	00-R Catalog No.	111-R Catalog No.	12-R Catalog No.
—	Ratchet and Handle Assembly	38540	38550	38555
1	Ratchet Assembly	38565	38575	38580
2	Handle	38590	38585	38585
3	Pin	38705	38705	38705
4	Knob	38700	38700	38700
5	Spring	38695	38695	38695
6	Pawl	38690	38690	38690

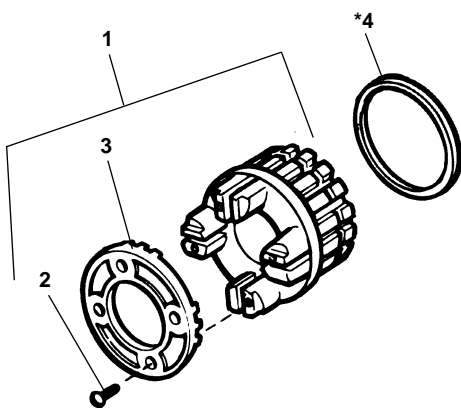

* Used on early models

Ref. No.	Description		00-R Catalog No.	111-R Catalog No.	12-R Catalog No.	12-R IMC Catalog No.
1	Die Head w/Cover Plate & Screws	1/8"	38710	38840	38890	—
		1/4"	38730	38850	38900	—
		3/8"	38740	38855	38905	—
		1/2"	38755	38860	38910	94060
		3/4"	38765	38865	38915	94065
		1"	38775	38870	38920	94070
		1 1/4"	—	38875	38925	94075
		1 1/2"	—	—	38930	94080
2	Cover Plate Screw (4)	1/8"-1/4"	38720	38720	38720	—
		3/8"-1 1/4"	38750	38750	38750	38750
		1 1/2"-2"	—	—	38940	38940
		2"	—	—	38945	94085
3	Cover Plate	1/8"	38715	38715	38715	—
		1/4"	38735	38735	38735	—
		3/8"	38745	38745	38745	—
		1/2"	38760	38760	38760	38760
		3/4"	38770	38770	38770	38770
		1"	38780	38780	38780	38780
		1 1/4"	—	38880	38880	38880
		1 1/2"	—	—	38935	38935
4	Spring Ring	2"	—	—	38950	38950
			*38725	*38845	*38895	—

RIDGID No. 00-RB Ratchet-Type Bolt Threader

Capacity: 1/4" through 1"

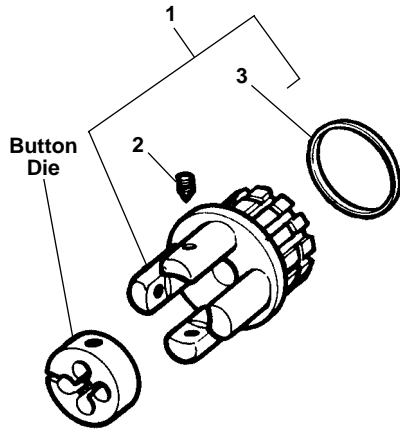

NOTE: Order parts by Catalog Number only.
DO NOT order by Reference Number.

Ref. No.	Catalog No.	Description
1	38960	1/4" Die Head
	38965	5/16" Die Head
	38970	3/8" Die Head
	38975	7/16" Die Head
	38980	1/2" Die Head
	38985	9/16" Die Head
	38990	5/8" Die Head
	38995	3/4" Die Head
	39000	7/8" Die Head
	39005	1" Die Head
2	39020	Screw (3)
3	38725	Spring Ring

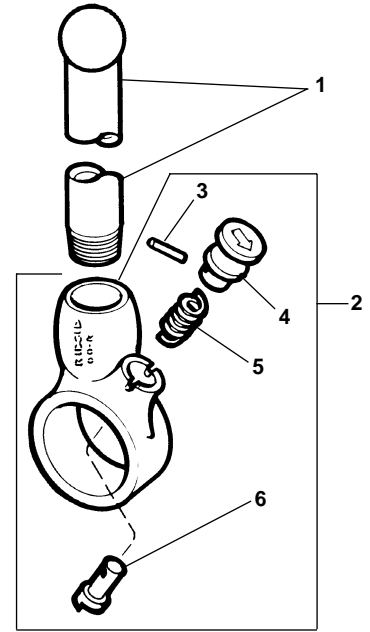

Ref. No.	Catalog No.	Description
—	38540	Ratchet & Handle Assembly
1	38590	Handle
2	38565	Ratchet Assembly
3	38705	Pin
4	38700	Knob
5	38695	Spring
6	38690	Pawl

NOTE: 3-Way Bolt Threader Dies are interchangeable with 00-RB Dies.

3-Way Bolt Threaders

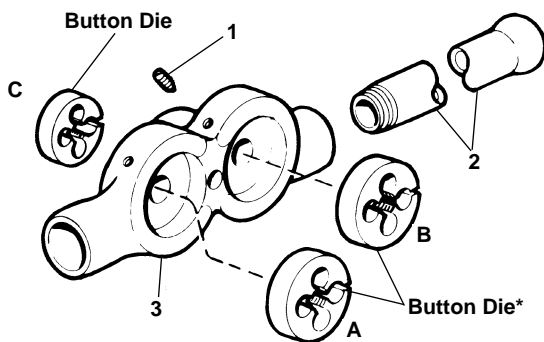

Ref. No.	Description	31-B	33-B	35-B	37-B
		1/4"-1/2"	3/8"-5/8"	1/2"-3/8"	3/4"-1"
Catalog No.		Catalog No.	Catalog No.	Catalog No.	Catalog No.
1	Screw (9)	39015	39015	39015	39015
2	Handle (2)	39045	39045	39045	39535
3	Body	39025	39030	39035	39040

* Refer to Die Table.



Model No.	Refer to A, B & C For Button Die Combinations											
	31-B			33-B			35-B			37-B		
O.D. of Button Die	1"	1"	1 1/2"	1"	1 1/2"	1 1/2"	1 1/2"	1 1/2"	1 1/2"	2"	2"	2 1/4"
Button Die Location	A	B	C	A	B	C	A	B	C	A	B	C
Rod Diameter	1/4"	3/8"	1/2"	3/8"	1/2"	5/8"	1/2"	9/16"	5/8"	3/4"	7/8"	1"
		5/16"	9/16"	1/4"		9/16"						
		7/16"	5/8"	5/16"								
				7/16"								

NOTE: 1. 00-RB Dies are interchangeable w/above Button Dies.

2. To use 7/16" Button Die in 31-B or 33-B enlarge Pilot Hole to 15/32".

3. To use 9/16" or 5/8" Button Dies in 31-B enlarge Pilot Hole to 19/32" or 21/32".