

Motor/Pump Assembly

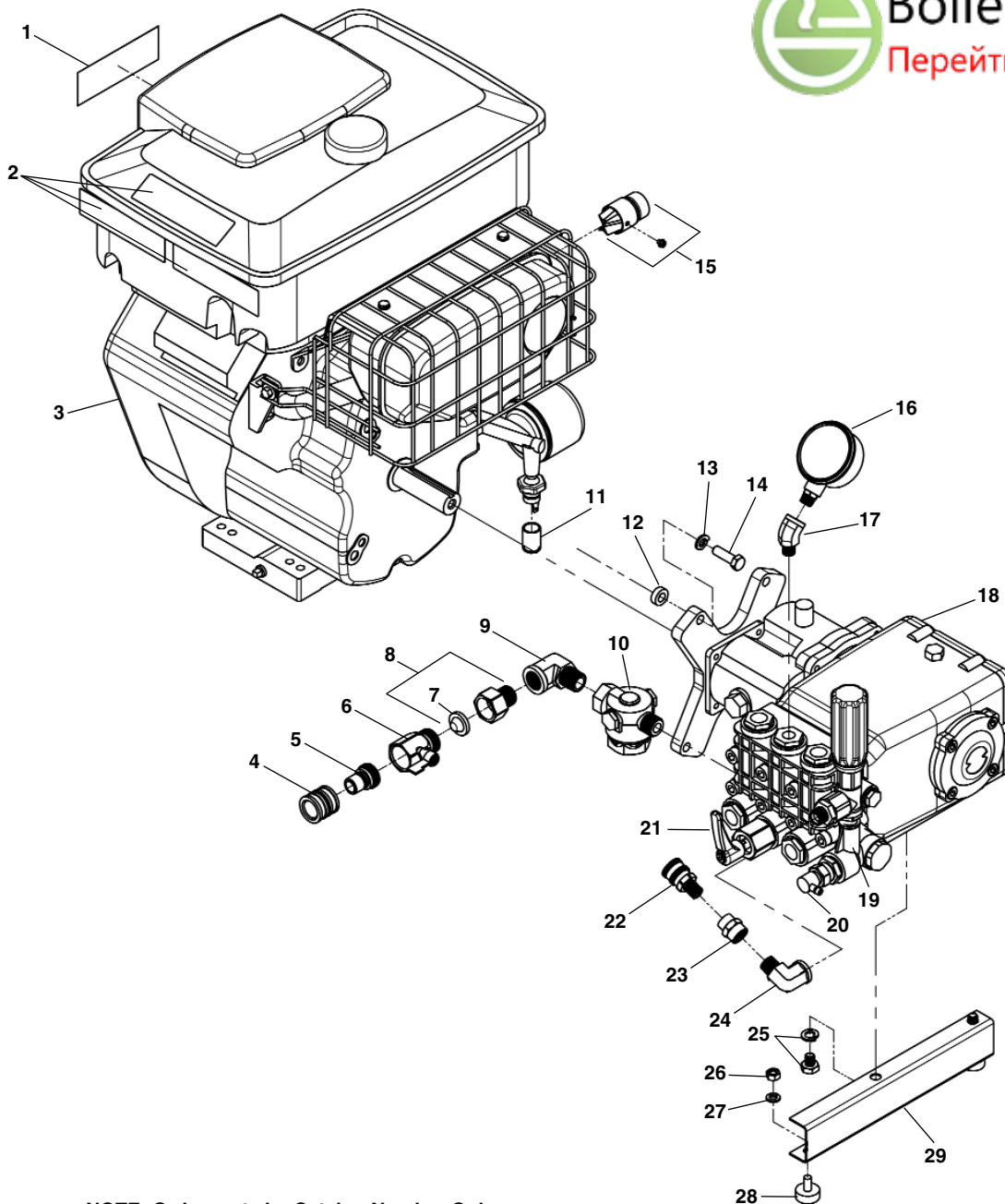

NOTE: Order parts by Catalog Number Only.  
DO NOT order by Reference Number.

Ref. No.	Catalog No.	Description	Ref. No.	Catalog No.	Description
1	60102	Decal, Fuel Warning	16	66117	Pressure Gauge
2	40218	Decal, Warning	17	48107	Street EL, 45 Degree
3	40203	Gasoline Engine, 16 Hp Manual Start	18	40208	Pump Asm Complete (Incl. 19, 20 & 21)
4	48197	Hose Coupler	19	40298	Unloader
5	48202	Hose Coupler Nipple	20	40313	Thermal Relief
6	49582	Water Shut-Off	21	40303	Pulse Assembly
7	48287	Filter Washer	22	48117	Quick Connect – Female
8	49587	Hose Adapter (Incl. Ref 7)	23	66157	Reducer Adapter
9	48147	Street EL, 90 Degree, 1/2" NPT	24	66162	Street EL, 90 Degree
10	66167	Inlet Filter	25	40183	Hex Cap Screw w/Washer M10 x 12 (2)
11	39363	Cap	26	60230	Hex Nut 5/16" - 18 (2)
12	40558	Spacer	27	60080	Lock Washer 1 1/32" (2)
13	60085	Lock Washer (4)	28	48187	Vibration Mount (2)
14	40563	Hex Screw, 3/8"	29	40198	Pump Support Bracket
15	40233	Spark Arrestor			

## Pump

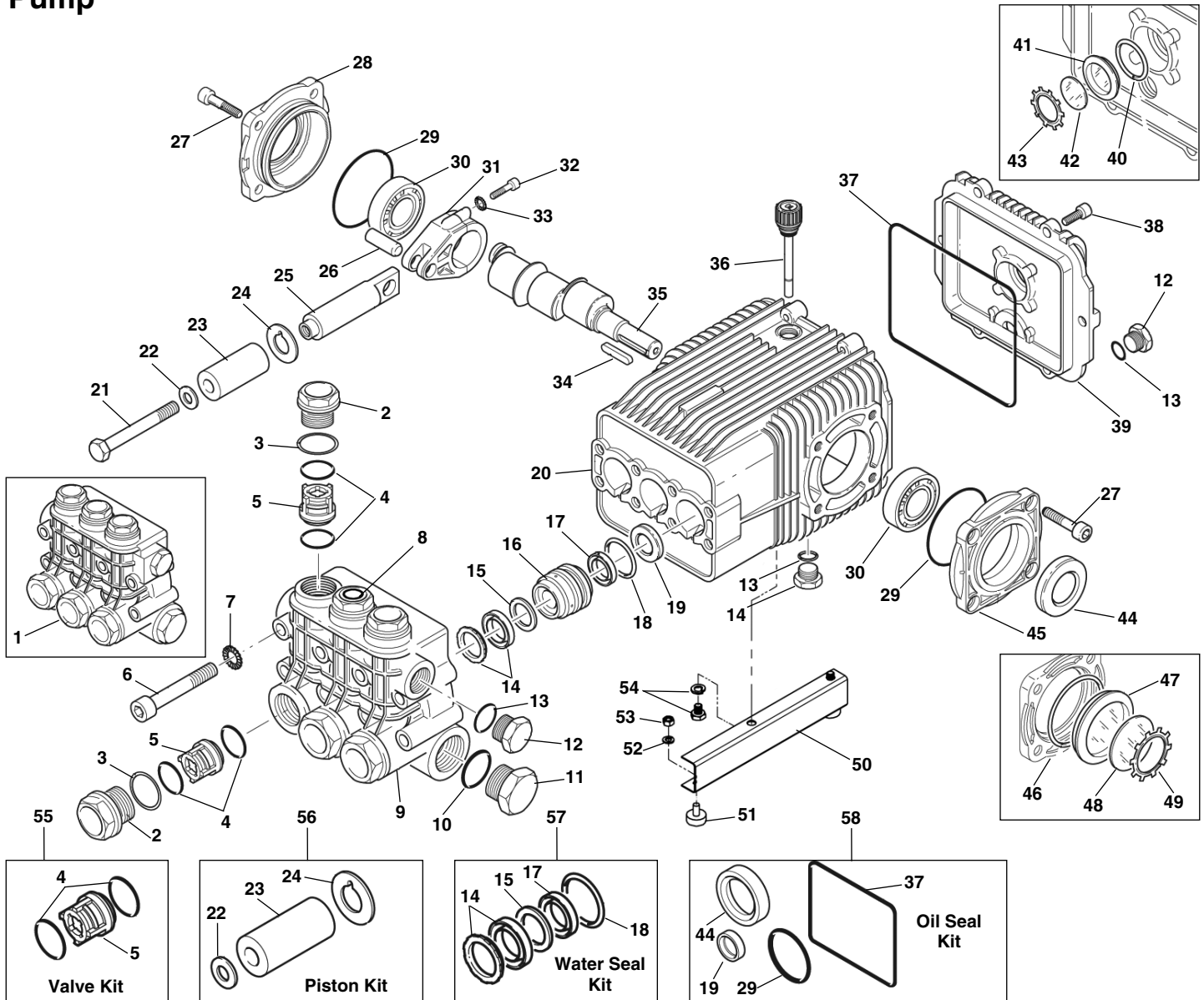

**NOTE: Order parts by Catalog Number Only.  
DO NOT order by Reference Number.**

Ref. No.	Catalog No.	Description	Ref. No.	Catalog No.	Description	Ref. No.	Catalog No.	Description
-	40288	Triplex Plunger Pump	20	39588	Pump Housing	40	39463	O-Ring Ø 20.24 x 2.62
1	39668	Complete Pump Head	21	39663	Bolt M6 x 60 (3)	41	39598	Oil Sight Glass
2	39453	Valve Cap (602 in/lbs) (6)	22	39523	Washer - Copper (3)	42	39623	Contrast Disc
3	39458	Ring (6)	23	39528	Piston (3)	43	39603	Snap Ring
4	39463	O-Ring Ø 20.24 x 2.62 (12)	24	39533	Spacer (3)	44	39633	Seal Ring
5	39468	Complete Valve (6)	25	39538	Guiding Piston (3)	45	39658	Open Bearing Support
6	39443	Head Bolt M10 x 80 (442 in/lbs) (8)	26	39543	Piston Pin (3)	46	39678	O-Ring Ø 34.6 x 2.62
7	39448	Lock Washer (8)	27	39563	Bolt M8 x 16 (217 in/lbs) (8)	47	39673	Oil Sight Glass
8	40308	Gauge Port Adapter	28	39558	Side Cover w/Sight Glass	48	39683	Contrast Disc
9	39473	Pump Head	29	39548	O-Ring Ø 66.34 x 2.62 (2)	49	39688	Seal
10	40278	O-Ring Ø 23.81 x 2.62	30	39568	Bearing (2)	50	40198	Pump Support Bracket
11	39483	Plug 3/4" G	31	39573	Con-Rod (89 in/lbs) (3)	51	48187	Vibration Mount (2)
12	39433	Plug 3/8" G (3)	32	39698	Con-Rod Bolt (6)	52	60080	Lock Washer 11/32" (6)
13	39493	O-Ring Ø 14 x 1.78 (3)	33	39693	Lock Washer (6)	53	60230	Hex Nut 3/16" - 18 (6)
14	39498	Gasket w/Ring (3)	34	39583	Key	54	40183	Hex Cap Screw w/Washer M10 x 12 (2)
15	39503	Front Piston Guide (3)	35	39578	Crankshaft 24mm	55	39703	Valve Kit
16	39508	Piston Guide (3)	36	39383	Oil Cap	56	39708	Piston Kit
17	39513	Gasket (3)	37	39608	O-Ring Ø 132 x 3	57	39713	Water Seal Kit
18	39518	O-Ring Ø 34.65 x 1.78 (3)	38	39613	Bolt M6 x 16 (89 in/lbs) (6)	58	39718	Oil Seal Kit
19	39638	Seal (3)	39	39618	Complete Cover			

**Cart with Hose Reel**

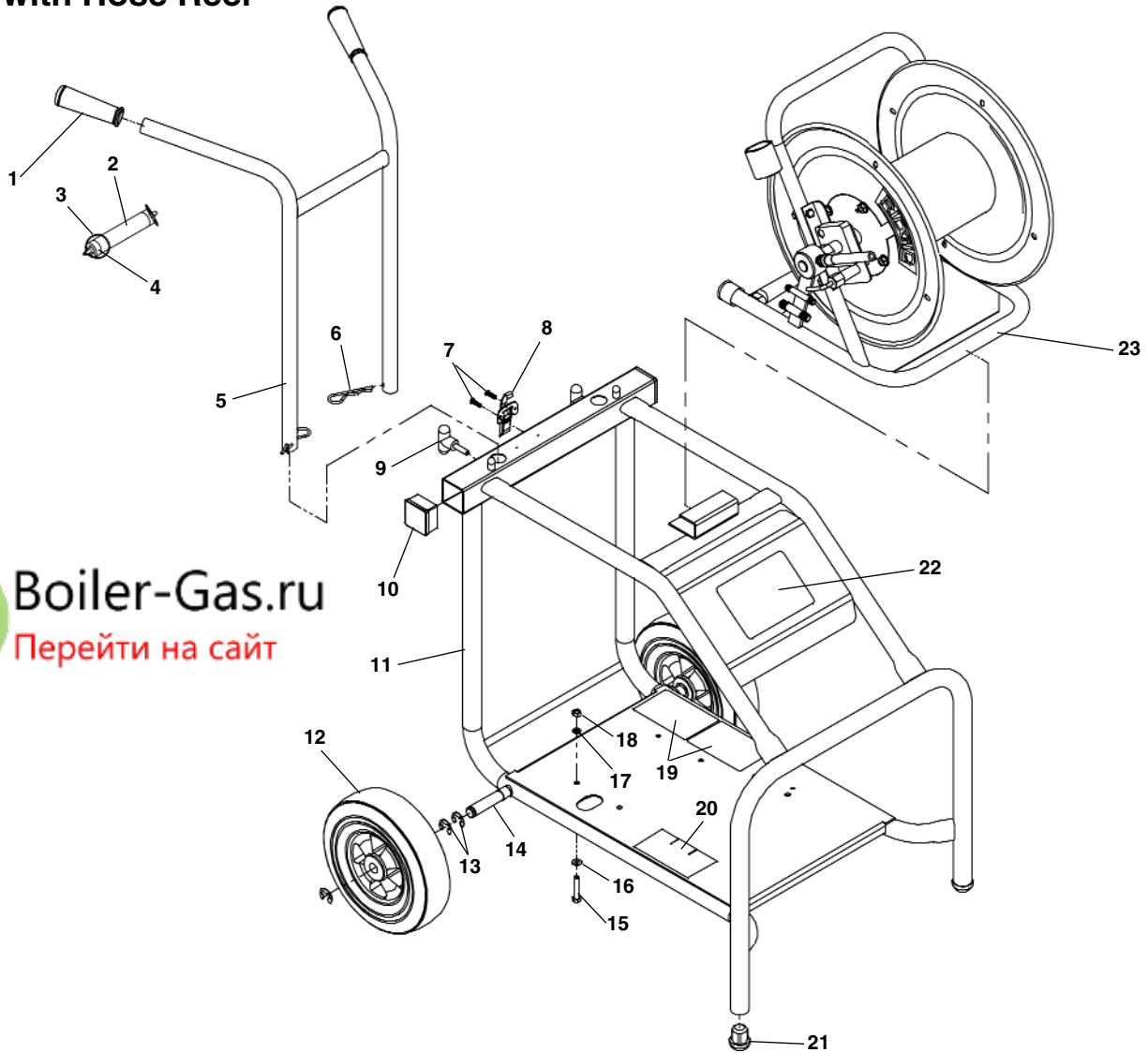

**NOTE: Order parts by Catalog Number Only.  
DO NOT order by Reference Number.**

Ref. No.	Catalog No.	Description
1	60827	Hand Grip (2)
2	27588	Operators Manual Tube
3	54562	Tool Ring
4	27593	Cap
5	66017	Handle Assembly
6	60677	Hairpin (2)
7	27017	Screw, Self Tapping #12-24 x 3/4" (2)
8	47972	Latch
9	60622	Mounting Knob (2)
10	66027	Square Plug (2)
11	40188	Frame
12	23597	Wheel (2)
13	60050	Retaining Ring (6)
14	40193	Axle
15	43992	Hex Screw 3/8"-16 x 2" (4)
16	59970	Flat Washer 3/8" (4)
17	60085	Lock Washer 3/8" (4)
18	60395	Hex Nut 3/8" (4)
19	40228	Engine Warning Label
20	40223	Instruction Label
21	61470	Rubber Plug (2)
22	40213	Model Number Label
23	64862	H-38 Hose Reel Assembly

## Gearbox

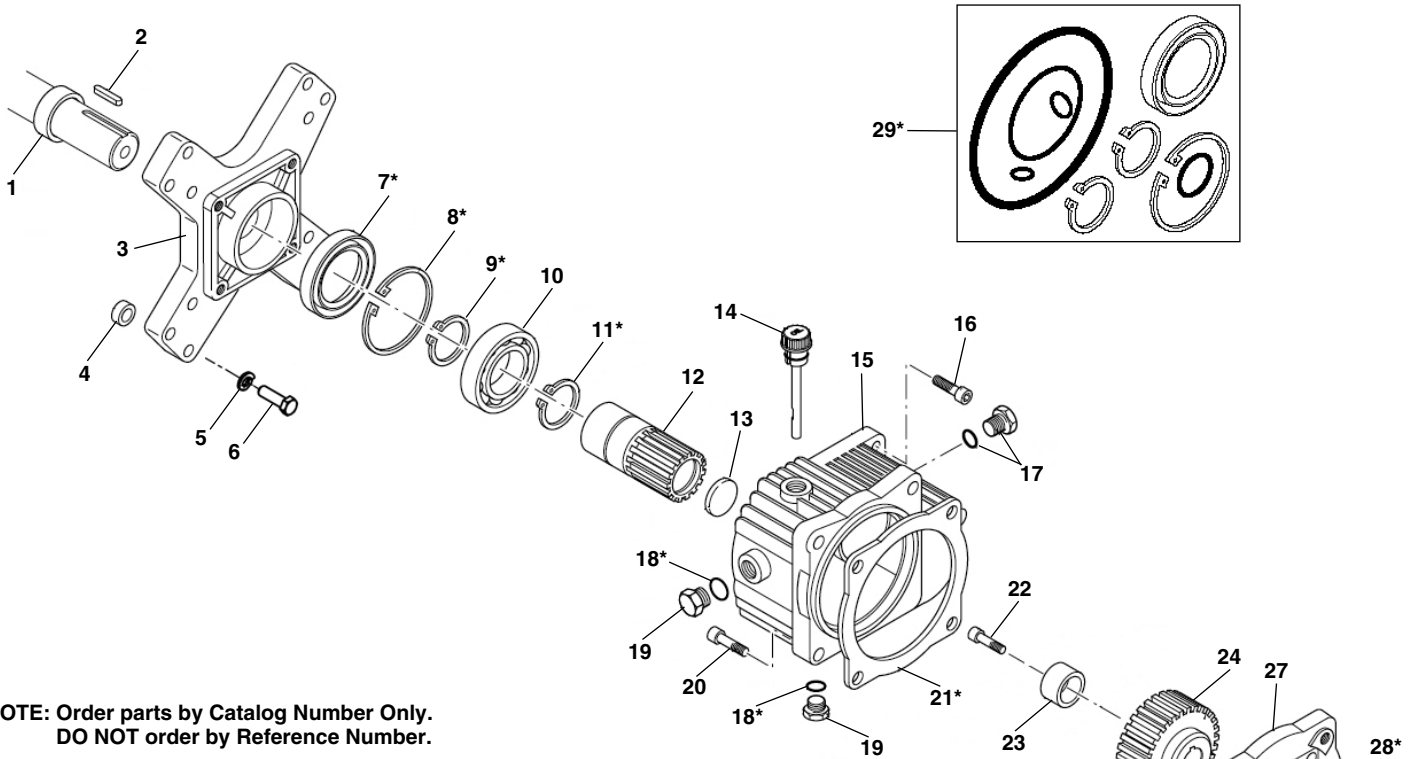

**NOTE: Order parts by Catalog Number Only.  
DO NOT order by Reference Number.**

Ref. No.	Catalog No.	Description	Ref. No.	Catalog No.	Description
—	40293	Gear Box Assembly	15	39388	Gear Box
1	39353	Spacer	16	39398	Screw (4)
2	39348	Key	17	39393	Plug
3	39358	Motor flange	18*	39368	O-Ring
4	40558	Spacer (4)	19	39433	Plug
5	60085	Lock Washer (4)	20	39438	Screw (4)
6	40563	Screw (4)	21*	39368	O-Ring
7*	39368	Seal	22	39403	Screw
8*	39368	Circlip	23	39408	Spacer
9*	39368	Circlip	24	39413	Gear
10	39373	Bearing	25	39428	Screw (4)
11*	39368	Circlip	26	39423	Washer (4)
12	39378	Pinion	27	39418	Flange
13	40568	Cover	28*	39368	O-Ring
14	39383	Oil Plug with O-Ring	29*	39368	Service Kit

\* Sold in Ref # 29 Service Kit only.

## FV-1 Foot Valve

Ref. No.	Catalog No.	Description
—	48157	Foot Valve Complete, FV-1
1	49787	Elbow w/Swivel, 1/4" NPT (2)
2	49777	Decal, Model No.
3	49772	Cover
4	36787	Screw, Self Tapping, #10 (4)
5	49792	Lock Washer 9/16" (2)
6	49797	Street EL, 1/4" NPT(2)
7	49782	Valve Assembly
8	49802	Carriage Bolt, 1/4" NPT
9	47297	Lock Nut, 1/4" - 20
10	49767	Foot Pedal
11	36737	Base
12	36747	Pivot Pin
13	48117	Quick Connect - Female

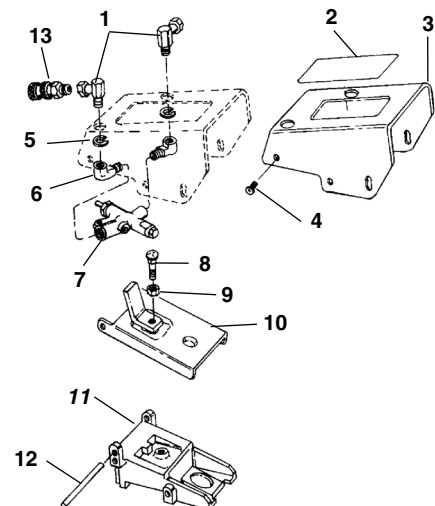

Unloader Valve - (Black Knob)

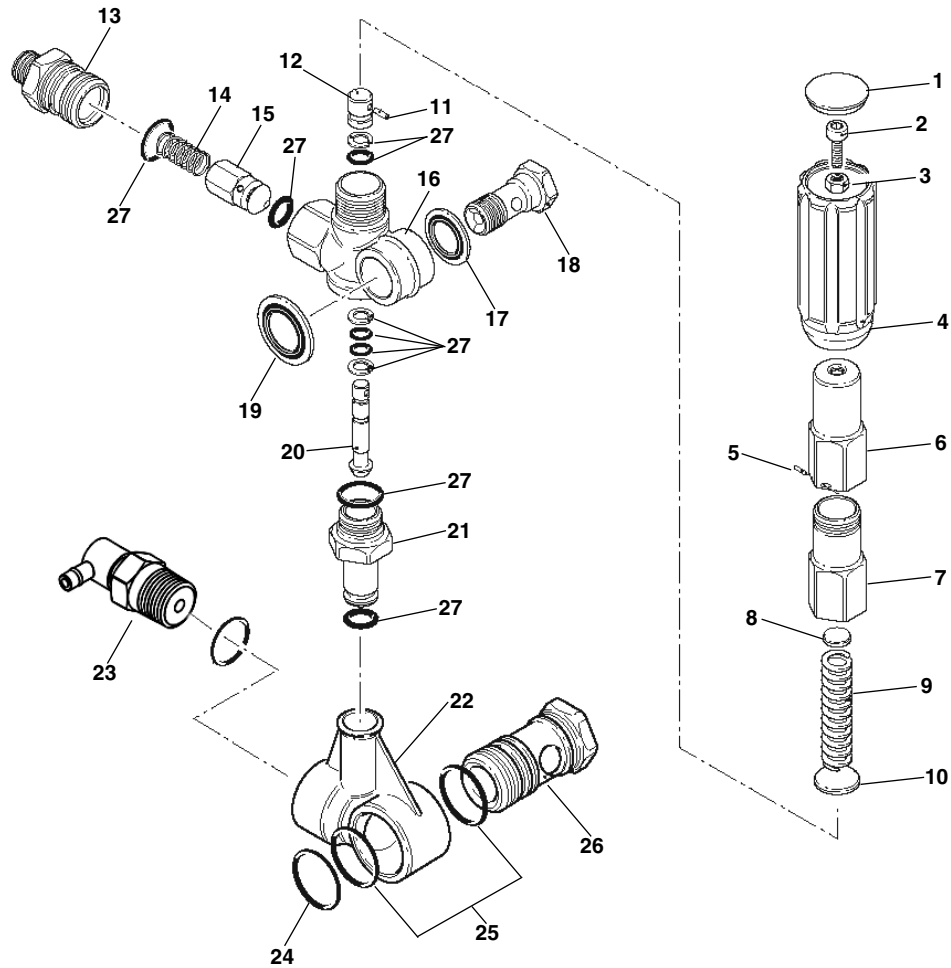

**NOTE: Order parts by Catalog Number Only.  
DO NOT order by Reference Number.**

Ref. No.	Catalog No.	Description
-	40298	Unloader Complete
1	39878	Knob Plug
2	39883	Bolt
3	39888	Nut
4	39893	Handle
5	39898	Pin
6	39903	Adjusting Screw
7	39908	Spring Guide
8	39913	Plate
9	39918	Spring
10	39923	Spring Plate
11	39928	Pin
12	39933	Upper Piston
13	40238	Brass Adaptor 3/8" G
14	39943	Spring
15	39938	Shutter Valve
16	39958	Valve Housing
*17	39953	Washer
18	39948	Fitting 3/8" G
*19	39963	Washer
20	39968	Lower Piston
21	39973	By-Pass Adaptor
22	39978	By-Pass Housing 3/4" G
23	40313	Thermal Relief
24	40278	O-Ring
25	40243	O-Ring (2)
26	39983	Brass Fitting 3/4" G
*27	39993	Repair Kit (* Incl in Kit)

## H-38 Reel Assembly

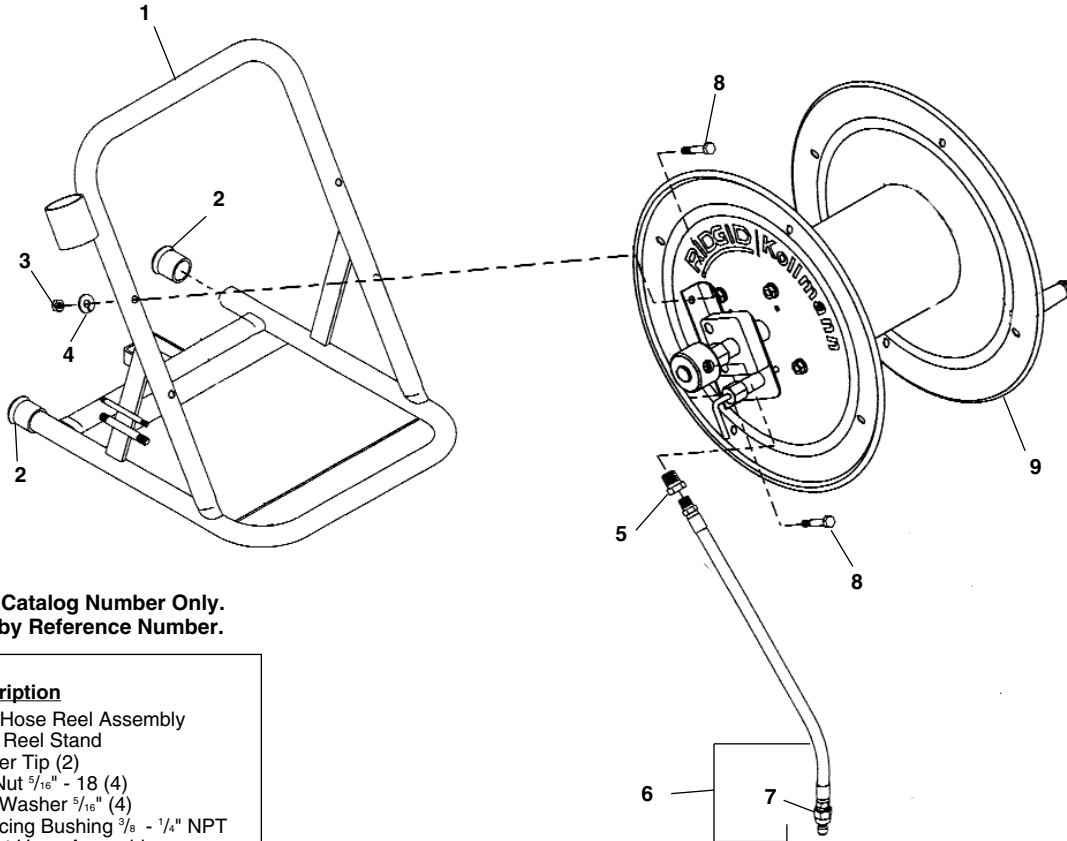
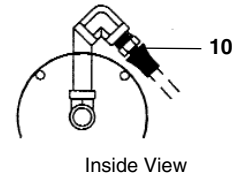
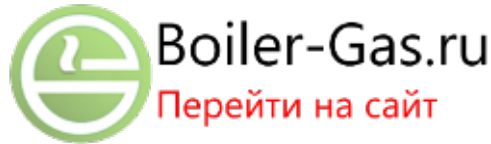

**NOTE: Order parts by Catalog Number Only.  
DO NOT order by Reference Number.**

Ref. No.	Catalog No.	Description
—	64862	H-38 Hose Reel Assembly
1	66022	Hose Reel Stand
2	37962	Rubber Tip (2)
3	60230	Hex Nut $\frac{5}{16}$ " - 18 (4)
4	60080	Lock Washer $\frac{5}{16}$ " (4)
5	48152	Reducing Bushing $\frac{3}{8}$ - $\frac{1}{4}$ " NPT
6	66047	Output Hose Assembly
7	48002	Quick Connect - Male
8	43847	Hex Screw $\frac{5}{16}$ " - 18 x $1\frac{1}{2}$ " (4)
9	48022	Hose Reel
10	35275	Spring

## Reel Components

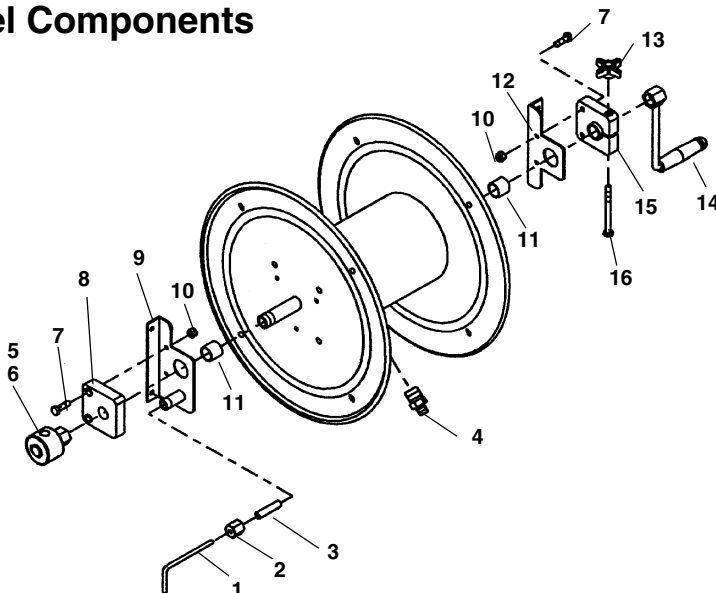

Ref. No.	Catalog No.	Description
—	48022	Hose Reel COMPLETE
1	67677	Reel Lock
2	67682	Lock Nut
3	67687	Sleeve
4	67692	Reducer Bushing, $\frac{1}{2}$ " - $\frac{1}{4}$ " NPT M
5	67697	Swivel Connector
6	67702	Service Kit, Swivel
7	85910	Hex Screw, $\frac{5}{16}$ " - 18 x 1" (2)
8	67707	Bearing Block, Plain
9	67712	Bracket, Lock Side
10	75110	Hex Nut, $\frac{5}{16}$ " - 18 (2)
11	67717	Spacer (2)
12	67727	Bracket, Plain
13	67732	Knob, Drag Brake
14	67737	Crank
15	67742	Bearing Block, Drag
16	67747	Hex Screw, $\frac{5}{16}$ " - 18 x $3\frac{1}{2}$ "