

**NOTE: Order parts by Catalog Number only.
DO NOT order by Reference Number.**

Ref. No.	Catalog No.	Description
—	23332	345 Flare Tool
—	23342	345M Flare Tool - Metric
1	96587	Feedscrew Assembly
2	96607	Clampscrew Assembly
3	96602	Flare Bar Assembly
	97482	Flare Bar Assembly Metric
4	96597	Pin
5	96592	Cone w/Pin
6	96612	Yoke

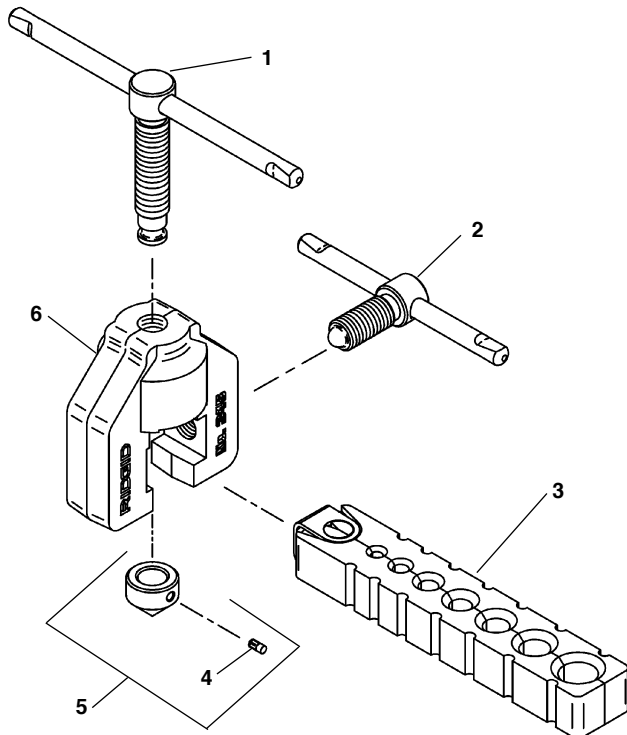

**NOTE: Order parts by Catalog Number only.
DO NOT order by Reference Number.**

Ref. No.	Catalog No.	Description
—	23332	345 Flare Tool
—	23342	345M Flare Tool - Metric
1	96587	Feedscrew Assembly
2	96607	Clampscrew Assembly
3	96602	Flare Bar Assembly
	97482	Flare Bar Assembly Metric
4	96597	Pin
5	96592	Cone w/Pin
6	96612	Yoke